



## **AGENDA**

### **N.C. WILDLIFE RESOURCES COMMISSION**

**December 10, 2015, 9:00 a.m.**

**1751 Varsity Drive**

**NCWRC Conference Room, 5<sup>th</sup> Floor**

**Raleigh, North Carolina**

**CALL TO ORDER** - *Chairman John Litton Clark*

**This meeting is being recorded as a public record and is audio streaming live at [www.ncwildlife.org](http://www.ncwildlife.org). As a courtesy to others please turn off all cell phones during the meeting.**

**PLEDGE OF ALLEGIANCE** – *Commissioner Dean Proctor*

**INVOCATION** - *Commissioner Tommy Fonville*

### **RECOGNITION OF VISITORS**

**MANDATORY ETHICS INQUIRY** - North Carolina General Statute 138A-15(e) mandates that the Commission Chair shall remind all Commissioners of their duty to avoid conflicts of interest and appearances of conflict under this Chapter, and that the chair also inquire as to whether there is any known conflict of interest or appearance of conflict with respect to any matters coming before the Commission at this time. It is the duty of each Commissioner who is aware of such personal conflict of interest or of an appearance of a conflict, to notify the Chair of the same. *Chairman Clark*

**SWEAR IN COMMISSIONER MARK CRAIG** – *Margo Minkler, Notary Public – Enforcement Division*

**APPROVAL OF OCTOBER 22, 2015 MINUTES** - Take action on the October 22, 2015 Wildlife Resources Commission meeting minutes as written in the exhibit and distributed to members (**EXHIBIT A**)

## **ADMINISTRATION**

**Financial Status Report** - Receive a financial status report on the Wildlife Operating Fund and Wildlife Endowment Fund – *Lindsey Riddick, Budget Analyst* (**EXHIBIT B**)

## **COMMITTEE REPORTS**

**Land Use and Access Committee Report** – *Tom Berry, Chair*

**Boating Safety Committee Report** – *Ray Clifton, Chair*

**Big Game Committee Report** – *Neal Hanks, Chair*

**AGENCY SPOTLIGHT** – Beyond Licensing - IT Initiatives for Customer Engagement and Staff Efficiency – *CarolAnne Feehan, IT Business Analyst*

## **INLAND FISHERIES DIVISION**

**Fisheries Update** – Receive an update on the activities of the Inland Fisheries Division – *Bob Curry, Inland Fisheries Division Chief*

## **WILDLIFE MANAGEMENT DIVISION**

**Wildlife Management Update** – Receive an update on the activities of the Wildlife Management Division – *Dr. David Cobb, Wildlife Management Division Chief*

## LAND AND WATER ACCESS SECTION

### Land Acquisitions and Property Matters

**Phase I Land Acquisitions** - Consider approval for staff to work with State Property Office and funding partners to develop acquisition plans for the following properties – *Isaac Harrold, Lands Program Manager* (**EXHIBITS C-1, C-2, C-3, C-4, C-5, C-6**)

- Collette Tract - Carteret County
- Lambb Lot 256 – Ashe County
- Little Macedonia Tract – Brunswick County
- Moorman Farms Tract – Washington County
- Pontiac Plywood Tracts – Warren County
- Tweed Tract – Buncombe County

**Phase II Land Acquisition, Haywood County** - Consider final approval to proceed with acquisition of the Caldwell Tract in Haywood County – *Isaac Harrold* (**EXHIBIT D**)

**Easement Request, Scotland County** - Consider a request from NC Department of Transportation for easements across a portion of Sandhills Game Land in Scotland County to facilitate a bridge improvement project – *Isaac Harrold* (**EXHIBIT E**)

**Easement Amendment Request, Polk County** - Consider a request to amend an existing utility easement across a portion of Green River Game Land in Polk County for the purpose of specifically defining the easement width and location – *Isaac Harrold* (**EXHIBIT F**)

## WATER SAFETY RULEMAKING

**Notice of Text for Permanent Rulemaking (15A NCAC 10F .0347)** – Consider recommendation to publish Notice of Text in the *NC Register* for a proposed no wake zone on a portion of Slocum Creek, requested by the City of Havelock in Craven County – *Betsy Haywood, No Wake Zone Coordinator* (**EXHIBIT G-1**)

**Fiscal Note** - Consider approval of fiscal note for the City of Havelock no wake zone – *Betsy Haywood* (**EXHIBIT G-2**)

**COMMENTS BY CHAIRMAN** – *John Litton Clark*

**COMMENTS BY EXECUTIVE DIRECTOR** – *Gordon Myers*

**ADJOURN**

# EXHIBIT A

December 10, 2015



## MINUTES

October 22, 2015

### N. C. Wildlife Resources Commission Meeting Raleigh, North Carolina

The October 22, 2015 N. C. Wildlife Resources Commission meeting was called to order by *Commission Chairman* John Litton Clark at 9:00 a.m. in the Commission Room at Wildlife Resources Commission Headquarters in Raleigh. Clark reminded everyone that the meeting audio is being streamed live and will be available on the Wildlife Resources Commission website. He requested that everyone silence electronic devices. Commissioners John Coley and Mark Craig were absent.

Commissioner Wes Seegars led the Pledge of Allegiance.

Commissioner Tim Spear gave the invocation.

### WELCOME AND MANDATORY ETHICS INQUIRY

Chairman Clark advised the Commission of the mandatory ethics inquiry as presented in the agenda. He welcomed Commissioners and guests, including families of Commissioners-elect Landon Zimmer, Richard Edwards, John Stone, and special guests Senator Bill Rabon and Representative Paul Stam.

### COMMISSIONER ATTENDANCE

Jim Cogdell  
Wes Seegars  
Landon Zimmer  
Ray Clifton  
Neal Hanks  
Tommy Fonville

Richard Edwards  
Tom Berry  
Tim Spear  
Garry Spence  
Brian White  
John Stone

Nat Harris  
Mike Johnson  
John Litton Clark  
Dean Proctor  
Joe Budd

## VISITORS

Patrick Mills	Patrick Mills, Jr.
Rebecca Stone	Jonathan Stone
Rachel Pratt	Abbie Edwards
Rick Edwards	Ronna Zimmer
Herbert Zimmer	Senator Bill Rabon
Eric Montross	Representative Paul Stam
Henri McClees – NC Sporting Dog Assn.	Dick Ludington
Joe McClees – NC Sporting Dog Assn.	

## NOTICES OF APPOINTMENT TO THE WILDLIFE RESOURCES COMMISSION

The Commission received into the minutes the Notices of Appointment by Governor Pat McCrory of Michael Johnson, District 8 and Richard Edwards, District 2 for terms ending June 30, 2021; Garry Spence, Mark Craig, Thomas Berry and Landon Zimmer on the recommendation by President Pro Tempore Phil Berger for terms ending June 30, 2017; and Thomas Fonville, Timothy Spear, Dean Proctor, and John Stone on recommendation by House Speaker Tim Moore for terms ending June 30, 2017. **Exhibits A-1, A-2, A-3, and A-4** are hereby incorporated into the official record of this meeting.

## WELCOME OF NEW COMMISSIONERS SWORN IN ON OCTOBER 20, 2015

Chairman Clark welcomed new Commissioners Mike Johnson, *District 8 Governor Appointee* and Dean Proctor, *House Speaker Appointee*, who were sworn in on October 20, 2015 in Hickory.

## STATE ETHICS COMMISSION REVIEW OF 2015 STATEMENTS OF ECONOMIC INTEREST FOR COMMISSIONERS

The Commission received into the Minutes in **Exhibit B**, evaluations by the N.C. Ethics Commission of the 2015 Statements of Economic Interest for Michael Johnson, Richard Edwards, Landon Zimmer, Dean Proctor and John Stone, pursuant to NCGS §138A-15(c). The evaluations in their entirety are incorporated into the official record of this meeting.

## SWEAR IN COMMISSIONERS RICHARD EDWARDS AND LANDON ZIMMER

Senator Bill Rabon swore in Commissioners Richard Edwards, *District 2 Governor Appointee*, for a term ending June 30, 2021, and Landon Zimmer, *President Pro Tempore Appointee*, for a term ending June 30, 2017.

## SWEAR IN COMMISSIONERS JOHN STONE AND TIMOTHY SPEAR

Representative Paul Stam swore in Commissioners John Stone and Timothy Spear, *House Speaker Appointees*, for terms June 30, 2017.

Chairman Clark called a short recess so that photographs of new Commissioners could be taken. The meeting reconvened at 9:20 am.

## VISITORS

Patrick Mills	Patrick Mills, Jr.
Rebecca Stone	Jonathan Stone
Rachel Pratt	Abbie Edwards
Rick Edwards	Ronna Zimmer
Herbert Zimmer	Senator Bill Rabon
Eric Montross	Representative Paul Stam
Henri McClees – NC Sporting Dog Assn.	Dick Ludington
Joe McClees – NC Sporting Dog Assn.	

## NOTICES OF APPOINTMENT TO THE WILDLIFE RESOURCES COMMISSION

The Commission received into the minutes the Notices of Appointment by Governor Pat McCrory of Michael Johnson, District 8 and Richard Edwards, District 2 for terms ending June 30, 2021; Garry Spence, Mark Craig, Thomas Berry and Landon Zimmer on the recommendation by President Pro Tempore Phil Berger for terms ending June 30, 2017; and Thomas Fonville, Timothy Spear, Dean Proctor, and John Stone on recommendation by House Speaker Tim Moore for terms ending June 30, 2017. **Exhibits A-1, A-2, A-3, and A-4** are hereby incorporated into the official record of this meeting.

## WELCOME OF NEW COMMISSIONERS SWORN IN ON OCTOBER 20, 2015

Chairman Clark welcomed new Commissioners Mike Johnson, *District 8 Governor Appointee* and Dean Proctor, *House Speaker Appointee*, who were sworn in on October 20, 2015 in Hickory.

## STATE ETHICS COMMISSION REVIEW OF 2015 STATEMENTS OF ECONOMIC INTEREST FOR COMMISSIONERS

The Commission received into the Minutes in **Exhibit B**, evaluations by the N.C. Ethics Commission of the 2015 Statements of Economic Interest for Michael Johnson, Richard Edwards, Landon Zimmer, Dean Proctor and John Stone, pursuant to NCGS §138A-15(c). The evaluations in their entirety are incorporated into the official record of this meeting.

## SWEAR IN COMMISSIONERS RICHARD EDWARDS AND LANDON ZIMMER

Senator Bill Rabon swore in Commissioners Richard Edwards, *District 2 Governor Appointee*, for a term ending June 30, 2021, and Landon Zimmer, *President Pro Tempore Appointee*, for a term ending June 30, 2017.

Chairman Clark called a short recess so that photographs of new Commissioners could be taken. The meeting reconvened at 9:20 am.

## MINUTES

On a motion by Garry Spence and second by Nat Harris, the Commission approved the August 27, 2015 Wildlife Resources Commission Minutes, presented in **Exhibit C**. The Minutes are hereby incorporated into the official record of this meeting.

## FINANCIAL STATUS REPORT

Lindsey Riddick, *Budget Analyst*, presented the financial status report on the Wildlife Operating Fund and the Wildlife Endowment Fund as of August 31, 2015 in **Exhibit D**. The Operating Fund balance was \$14,048,843.95. The Endowment Fund balance was \$114,094,688.13. Expendable interest was \$20,328,943.12. Riddick reported that for FY 2015-16 there is an agency reduction of \$3,090,990.00 of which \$1 million is a non-recurring reduction that will be covered with cash on hand. **Exhibit D** is hereby incorporated into the official record of this meeting.

## COMMITTEE REPORTS

**Executive Committee Meeting Report** – *Chairman* John Litton Clark reported that the Executive Committee met on October 21, 2015. Erik Christofferson, *Deputy Director of Operations*, provided an overview of the Lake Mattamuskeet Lodge. In 2006 Congress conveyed the lodge and 6.25 acres to North Carolina, under the Department of Cultural Resources. The Wildlife Resources Commission was invited to restore the facility, which will be used as an educational facility. The agency entered into a Memorandum of Agreement with the Department of Cultural Resources and U.S. Fish and Wildlife Service. Mark Williard, *Architect*, oversees the facility restoration. Williard discussed the construction of the building in 1915 as a pump station. Later from 1937 to 1974 the building was a lodge. Since the lodge was conveyed to the State, inadequate funding has resulted in the renovation project not being completed. Funding is being sought, an initial business plan has been presented, and Legislators will be invited to a two-day event to promote the heritage of the Lodge.

**Small Game and Wild Turkey Committee Meeting Report** – *Chairman* Garry Spence reported that the committee met with a large crowd in the first floor auditorium on October 21, 2015. Mike Fies of the Virginia Department of Game and Inland Fisheries presented a program about Virginia fox preserves that were built in the 1980s. Virginia has 36 preserves; North Carolina has five times as many. Fies stated that the fox preserves provide quality foxhound training opportunities. He discussed the requirements for holding gray and red foxes only and stated that the number taken in preserves is only 4 percent of the average fox harvest. The agency was directed by the Virginia Legislature to make improvements in management after controversy with the Humane Society of the United States. Numerous studies and surveys have improved the management of fox preserves and Field Trials. Under a 2014 compromise with HSUS, fox pens will be phased out over 40 years, stopping after July 1, 2054. North Carolina has fewer regulations than Virginia does.

Chris Kreh, *Upland Game Bird Biologist*, presented an overview of a proposed turkey gobbling chronology study. The study will research the effect of timing of the spring turkey season based on gobbling activity and breeding. Acoustic recorders will be used in a pilot project in the spring, prior to their use statewide.

**Land Use and Access Committee Meeting Report** – Tom Berry, *Chairman*, reported that the Land Use and Access Committee met in the Commission Room on October 21, 2015. The committee reviewed four Phase I properties and will recommend that the WRC approve staff working with the State Property Office and funding partners to develop acquisition plans for the properties. The Committee then reviewed four Phase II land acquisition proposals. The committee will recommend that the Commission approve the properties for acquisition.

Discussion was held about decreasing funding from Pittman-Robertson funds. The Committee requested that staff prioritize the potential acquisitions for the best use of the limited funds.

The Cleveland County shooting range is scheduled to have a ribbon cutting in January 2016. There has been no action by the WRC on a proposed Burke County shooting range.

**Fisheries Committee Meeting Report** - Tim Spear, *Chair*, reported that the Fisheries Committee met on October 21, 2015. Christian Waters reviewed the request by the Community of Todd to be added as a Mountain Heritage Trout City.

Bob Curry, *Inland Fisheries Division Chief*, provided an update on Whirling Disease, a parasitic disease that is affecting some trout populations in the Watauga River. Information about the disease will be presented to Fisheries Chiefs throughout the southeastern states.

Discussion was held about management issues at Lake Mattamuskeet, including nutrient loading, aquatic vegetation, and defective gates. There is frustration about the lack of interest by the USFWS in lake level management. Cindy Dohner, USFWS, plans to meet with Gordon Myers and several Commissioners at the SEAFWA Conference in Asheville to discuss management of Lake Mattamuskeet. The Fisheries Committee instructed staff to explore options for lake level management, including transfer of the Lake to the State of North Carolina.

Christian Waters discussed the possibility of stocking red drum at Lake Hyco as a management tool for tilapia populations, as well as a recreational fishing opportunity. In a project with NCSU, historic water quality data is being collected at Lake Hyco. Public meetings will be held to determine whether there is an interest in stocking triploid red drum.



**Joint Big Game and Habitat, Nongame and Endangered Species Committee Meeting Report**

– Neal Hanks, *Big Game Chairman*, reported that the joint committee met on October 21. Justin McVey provided an update on the status of elk in North Carolina. Discussion was held about consideration of an elk hunting season from October 1 to November 1, by permit only.

David Sawyer provided an update on the 2014 bear harvest. The 2012 Bear Management Plan was adopted by the WRC, using regulated hunting to achieve and maintain bear population objectives. In 2014 rules were passed allowing the use of unprocessed food by still hunters. New bear seasons were created in Piedmont counties and in Robeson County. Sawyer’s presentation included harvest data in 2014, when the mast crop was the second highest ever. 2015 mountain bear harvest is ongoing and so far there is a huge increase in bear harvest with the use of dogs. Sawyer stated that data is collected now on an annual basis with the development of the bear E-stamp in 2014.

Several attendees expressed concern that the bear population in eastern North Carolina is too high and that the Commission needs to evaluate options to address these concerns.

**Committee of the Whole Meeting Report** – John Litton Clark, *Chair*, reported that the Committee of the Whole met on October 21. New Commissioners were welcomed. Commissioners Tom Berry, Tommy Fonville and Garry Spence were sworn in by Margo Minkler, *Notary Public, Enforcement Division*.

Rules proposals to be considered at state-wide public hearings were discussed, with a recommendation that they be approved at the Commission meeting on October 22.

Gordon Myers recommended that the Commission adopt an additional meeting on December 10, with a Commissioner orientation on December 9.

Bob Curry gave a brief update on the SEAFWA meeting that will be held in Asheville. Cindy Dohner and David Viker of the USFWS will meet with Gordon Myers and Commissioners on November 3 in Asheville, regarding management of Lake Mattamuskeet.

**AGENCY SPOTLIGHT – LAW ENFORCEMENT PROFESSIONAL STANDARDS**

The Commission received an update about Law Enforcement Professional Standards from Lieutenant Sam Craft, *Law Enforcement Division*. The agency developed an Internal Affairs Department with a position created for Professional Standards Lieutenant. Craft stated that his responsibilities include protecting the credibility of the agency and law enforcement officers, assisting in standardizing forms and procedures, and investigating allegations of criminal conduct or egregious policy violations. In-service training includes review and adjustment of policies as needed. Craft stated that the Farm Act of 2015 requires Law Enforcement to report to the Joint Legislative Oversight Committee on Justice and Public Safety by March 1, 2016, and he will be involved in that process.

## HABITAT CONSERVATION UPDATE

Shannon Deaton, *Habitat Conservation Section Chief*, provided an update about recent activities of the Habitat Conservation Section. The program works with towns and cities and developers to provide information about conservation of wildlife habitats. Deaton stated that the Wildlife Action Plan revision will be submitted to the USFWS by September 25, 2015. Deaton thanked Neuse Sport Shop for their donation of tee shirts and stated that the business is a long-time supporter of wildlife diversity.

## WILDLIFE EDUCATION UPDATE

Kris Smith, *Wildlife Education Division Chief*, provided an update about the activities of the Wildlife Education Division. Smith announced that the 2016 Wildlife calendar was awarded first place by the Association for Conservation Information. Magazine Editor Interviews are being scheduled. Other recent activities include the first collegiate archery competition, FFA Camp that was held at White Lake, National Hunting and Fishing Day which involved 800 participants who came out in bad weather for the event, and outreach with the "Back in the Woods Again" program providing the use of track chairs for handicapped sportsmen.

## INLAND FISHERIES

### Fisheries Update

Bob Curry, *Inland Fisheries Division Chief*, provided an update about the activities of the Inland Fisheries Division. Curry stated that Atlantic sturgeon in the Roanoke River are being fitted with transmitters in collaboration with the Division of Marine Fisheries. Curry stated that a Trout Health meeting was held in Asheville.

### Community of Todd – Mountain Heritage Trout City Request

On a motion by Tim Spear and second by Brian White, the Commission approved a request by the Community of Todd, presented in **Exhibit E**, to be recognized as a Mountain Heritage Trout City and to recognize the Delayed Harvest Trout Waters section of the South Fork New River adjacent to Todd Island Park as Mountain Heritage Trout Waters. **Exhibit E – Community of Todd Mountain Heritage Trout City Request**, is hereby incorporated into the official record of this meeting.

## PROPOSED CHANGES IN FISHING REGULATION FOR 2016-2017 RECOMMENDED BY AGENCY STAFF FOR PUBLIC NOTICE AND PRESENTATION AT NINE PUBLIC HEARINGS

Bob Curry presented in **Exhibit F-1** the following proposed changes in inland fishing rules for 2016-2017 to take to state-wide public hearings in January 2016. Tim Spear made a motion to approve the proposals. Nat Harris seconded. The motion carried. **Exhibit F-1** is hereby incorporated into the official record of this meeting.

## **Trout**

- 1) Modify the lower boundary of Delayed Harvest Trout Waters on the Ararat River in Surry County, adding approximately 1.2 miles of Public Mountain Trout Waters. The designated reach will be the portion of the Ararat River adjacent to the Ararat River Greenway in Mount Airy.  
*15A NCAC 10C.0205 Public Mountain Trout Waters*
- 2) Modify the lower boundary of Hatchery Supported Trout Waters on the East Prong Roaring River in Wilkes County, removing approximately 1.3 miles of Public Mountain Trout Waters. The designated reach will be from the Stone Mountain State Park lower boundary to the S.R. 1002 bridge.  
*15A NCAC 10C.0205 Public Mountain Trout Waters*
- 3) Clarify that the portion of Three Top Creek located on Three Top Creek Game Land in Ashe County is classified as Hatchery Supported Trout Waters.  
*15A NCAC 10C.0205 Public Mountain Trout Waters*
- 4) Clarify the upper boundary of Hatchery Supported Trout Waters on Savannah Creek in Jackson County. The designated reach will be from Shell Branch to Cagle Branch.  
*15A NCAC 10C.0205 Public Mountain Trout Waters*

## **Black Bass**

- 1) Establish an exception to the general statewide regulation for black bass in Lake Chatuge (Clay County) by increasing the daily creel limit from 5 fish to 10 fish in aggregate, decreasing the minimum size limit for Largemouth Bass from 14 inches except that two fish less than 14 inches can be retained in the daily creel to 12 inches with no exception, and removing the minimum size limit of 14 inches for Smallmouth and Spotted Bass.  
*15A NCAC 10C.0305 Black Bass*
- 2) Establish an exception to the general statewide regulation for black bass in Lake Hampton (Yadkin County) by allowing no Largemouth Bass between 16 and 20 inches to be possessed. The daily creel limit will remain 5 fish, and the minimum size limit will remain 14 inches except that two fish less than 14 inches can be retained in the daily creel.  
*15A NCAC 10C.0305 Black Bass*
- 3) Modify the exception to the general statewide regulation for black bass in the New River in Alleghany County downstream of Fields Dam (Grayson County, Virginia) by increasing the slot limit of 14 to 20 inches with only one fish greater than 20 inches to a slot limit of 14 to 22 inches with only one fish greater than 22 inches. The daily creel limit will remain 5 fish.  
*15A NCAC 10C.0305 Black Bass*

## **Crappie**

- 1) Establish an exception to the general statewide regulation for crappie in Lake Chatuge (Clay County) by implementing 30-fish daily creel limit. There is no minimum size limit.  
*15A NCAC 10C.0306 Crappie*

- 2) Establish an exception to the general statewide regulation for crappie in Lake Hampton (Yadkin County) by implementing an 8-inch minimum size limit and a 20-fish daily creel limit.

*15A NCAC 10C.0306 Crappie*

### **Striped Bass and Bodie Bass (Hybrid Striped Bass)**

- 1) Establish an exception to the general statewide regulation for Striped Bass and Bodie Bass in Lake Chatuge (Clay County) by increasing the daily creel limit from four fish to 15 fish in aggregate, removing the minimum size limit of 20 inches, and allowing only two fish greater than 22 inches to be retained.

*15A NCAC 10C.0314 Striped Bass*

### **White Perch**

- 1) Prohibit transport, possession or release of live White Perch in waters in and west of Haywood, Buncombe, and Rutherford counties.

*15A NCAC 10C.0319 White Perch*

### **Blue Catfish**

- 1) Establish an exception to the general statewide regulation for Blue Catfish in Lake Tillery, Lake Wylie, and Mountain Island Reservoir by allowing only one fish greater than 32 inches to be possessed in the daily creel.

*15A NCAC 10C.0401 Manner of Taking Nongame Fishes: Purchase and Sale*

### **Atlantic Sturgeon**

- 1) Designate Atlantic Sturgeon as State Endangered when found in inland fishing waters and remove Atlantic Sturgeon from the State Special Concern list. The scientific name of Atlantic Sturgeon will be updated to match currently accepted nomenclature.

*15A NCAC 10I.0103 Endangered Species List*

*15A NCAC 10I.0105 Special Concern Species List*

### **Equipment**

- 1) Add dip nets when used in conjunction with a licensed hand-crank electrofisher where authorized by local law to the list of equipment that can be used to take nongame fish for bait or personal consumption in inland fishing waters with an inland fishing license.

*15A NCAC 10C.0402 Taking Nongame Fishes for Bait or Personal Consumption*

## **FISCAL NOTE APPROVAL FOR PROPOSED FISHERIES RULES**

On a motion by Wes Seegars and second by Garry Spence, the Commission approved the fiscal note review for proposed fisheries rules presented in **Exhibit F-2**. **Exhibit F-2** is hereby incorporated into the official record of this meeting.

## **WILDLIFE MANAGEMENT**

### **Wildlife Management Update**

Dr. David Cobb, *Wildlife Management Division Chief*, presented an update about the activities of the Wildlife Management Division. Cobb stated that the Division has been providing technical guidance to private landowners on a variety of issues. There has been collaboration on seventy projects, providing biological and human dimensions information. Currently the division is involved with 36 research projects, including management of cervids on the Albemarle Peninsula, the Urban Bear Study, the home range of painted buntings, NCSU study of huntable land, and collaboration between the WRC and UNC on the restoration of submerged aquatic vegetation in Lake Mattamuskeet.

## **2016-2017 RULE PROPOSALS FOR HUNTING, TRAPPING AND OTHER REGULATED ACTIVITIES FOR CONSIDERATION AT STATE-WIDE PUBLIC HEARINGS**

On a motion by Tom Berry and second by Tim Spear, the Commission voted to take to statewide public hearings in January 2016 proposed changes in hunting, trapping, and other regulated activities for 2016-2017, presented in **Exhibit G-1**. **Exhibit G-1** is hereby incorporated into the official record of this meeting.

### **Deer**

- 1) Allow the sale of raw (untanned) deer hides from an animal lawfully taken by hunting, because of depredation, or as road kill.

*15A NCAC 10B .0118 Sale of Wildlife*

### **Bear**

- 1) Change the definition of a bear cub from any bear weighing less than 50 pounds to any bear weighing less than 75 pounds.

*15A NCAC 10B .0107 Black bear*

- 2) Remove Gum Swamp from the bear sanctuary program.

*15A NCAC 10B .0202 Bear*

## **Alligators**

- 1) Allow hunting of alligators under the following conditions:
  - The season for American alligators is from September 1 to October 1.
  - Hunting is by permit only.
  - The bag limit is one per permit.
  - Manner of take is: catch pole, harpoon, gig, wooden peg, bang stick, archery equipment and artificial lights. Firearms shall only be used to dispatch American alligators that are restrained.

*15A NCAC 10B .0224 Alligator*

## **Elk**

- 1) Open an elk hunting season with the following restrictions:
  - The season for elk is from October 1 to November 1.
  - Hunting is by permit only.
  - The bag limit is one per permit.
  - Elk may be taken by any legal firearm or archery equipment.

*15A NCAC 10B .0225 Elk*

## **Sunday Hunting**

- 1) Hunting is limited to any landowner or member of the landowner's family, or any Pursuant to S.L. 2015-144, allow hunting on Sundays with firearms on private lands with the following restrictions:
  - person with written permission from the landowner.
  - Hunting on Sunday between 9:30 A.M. and 12:30 P.M. is prohibited, except on controlled hunting preserves licensed pursuant to N.C.G.S. § 113-273(g).
  - Hunting of migratory birds on Sunday is prohibited.
  - The use of a firearm to take deer that are run or chased by dogs on Sunday is prohibited.
  - Hunting on Sunday within 500 yards of a place of worship or any accessory structure thereof, or within 500 yards of a residence not owned by the landowner, is prohibited.
  - Hunting on Sunday in a county having a population greater than 700,000 people is prohibited (currently Wake and Mecklenburg counties).

Note: This proposal pertains only to hunting on Sundays with firearms. It does not affect current rules allowing hunting on Sundays with archery equipment.

*15A NCAC 10B .0201 Manner of Take*

## Listed Species

- 1) Designate the Red Knot and the Northern Long-eared Bat as federally-listed threatened species in North Carolina.  
*15A NCAC 101.0104 Threatened Species*
- 2) Remove the Eastern Cougar from the list of federally-listed endangered species in North Carolina.  
*15A NCAC 101.0103 Endangered Species*
- 3) Remove elk from the list of special concern species in North Carolina.  
*15A NCAC 101.0105 Special Concern*

## Wildlife Damage Control Agents

- 1) Allow for Wildlife Damage Control Agents (WDCAs) to renew their status every three years by attending the Commission's training course or completing an equivalent in continuing education courses.  
*15A NCAC 10B.0106 Wildlife Taken for Depredations*

## FISCAL NOTE – 2016-2017 RULE PROPOSALS FOR WILDLIFE MANAGEMENT

Upon a motion by Tim Spear and second by Nat Harris, the Commission approved the fiscal note for proposed rules pertaining to wildlife management presented in **Exhibit G-2**. **Exhibit G-2** is hereby incorporated into the official record of this meeting.

## PROPERTY MATTERS

**Phase I Potential Land Acquisitions** – On a motion by Tom Berry and second by Tommy Fonville, the Commission approved the presentation by Isaac Harrold, *Lands Program Manager* in **Exhibits H-1, H-2, H-3, and H-4** authorizing staff to work with the State Property Office and funding partners to develop acquisition plans for the following properties:

- Buck Rub Tract - Richmond County
- Hutchinson Tract – Richmond County
- Hwy 172 – Pilchers Branch Tracts – Onslow County
- Cumberland Farms Tract – Cumberland County

**Exhibits H-1, H-2, H-3 and H-4** are hereby incorporated into the official record of this meeting.

**Phase II Land Acquisitions** – On a motion by Tom Berry and second by Tommy Fonville, the Commission gave final approval to proceed with acquisitions of the following properties presented in **Exhibits I-1, I-2, I-3, and I-4**:

- Brinn Tract (donation) – Perquimans County
- Little Cove Creek – Polk County
- Tom Godwin Tract – Scotland County
- Town of Cary Olive Chapel Road Tract (donation) – Wake County

**Exhibits I-1, I-2, I-3, and I-4** are hereby incorporated into the official record of this meeting.

### **LAND MANAGEMENT RULE PROPOSALS APPROVED FOR PUBLIC NOTICE AND PRESENTATION AT PUBLIC HEARINGS**

Isaac Harrold, *Lands Program Manager*, presented **Exhibit J-1**, proposed changes in game land management rules. On a motion by Tom Berry and second by Nat Harris, the Commission adopted the following game land management rules for presentation at statewide public hearings:

#### **Deer**

1) Move the opening date for hunting deer with all lawful weapons on Lake Mattamuskeet and Alligator River National Wildlife Refuges from the Saturday on or nearest October 15 to the Saturday on or nearest September 10.

*15A NCAC 10B .0203 Deer*

#### **Applying to Game Lands Generally**

1) Prohibit all public use from sunset to sunrise on those portions of game land posted as “Day Use Only Zones”.

*15A NCAC 10D .0102 General regulations regarding use*

2) Modify existing game land rules regarding the possession of firearms on US Army Corps of Engineers (USACE) project lands and waters to comply with current applicable federal regulations contained in the Code of Federal Regulations, Title 36, Chapter III, Part 327.13.

*15A NCAC 10D .0102 General regulations regarding use*

#### **Applying to Specific Game Lands**

1) Allow youth to hunt in managed waterfowl impoundments from ½ hour before sunrise until sunset on the two youth waterfowl days following the end of the regular waterfowl seasons.

*15A NCAC 10D .0103 Hunting on game lands*



2) Prohibit the use of dogs for pursuing or taking foxes during the period of March 15 through July 15 on Bladen Lakes State Forest Game Land in Bladen County.

*15A NCAC 10D .0103 Hunting on game lands*

3) Expand the opportunity for horseback riding on R. Wayne Bailey-Caswell Game Land by allowing horses on gated roads and trails that are posted for equestrian use.

*15A NCAC 10D .0103 Hunting on game lands*

4) Remove text from the North Carolina Administrative Code which establishes Catawba Game Land in Catawba County.

*15A NCAC 10D .0103 Hunting on game lands*

5) Allow horseback riding on Chowan Swamp Game Land anytime from May 16 through August 31 and on Sundays only from September 1 through May 15 on those roads that are open to vehicular traffic and on those gated roads and trails that are specifically posted for equestrian use.

*15A NCAC 10D .0103 Hunting on game lands*

6) Remove posted Archery Zones from the permit requirement for hunting turkeys on Harris Game Land.

*15A NCAC 10D .0103 Hunting on game lands*

7) Designate Holly Shelter Game Land as a 6 day per week game land and restrict dog hunting for deer and bear to Mondays, Wednesdays and Saturdays, except as otherwise authorized by permit on the Bear Garden Tract of Holly Shelter Game Land.

*15A NCAC 10D .0103 Hunting on game lands*

8) Allow geocaching on Holly Shelter and Stones Creek Game Lands during closed seasons and on closed days for taking bear, deer, turkey and waterfowl.

*15A NCAC 10D .0103 Hunting on game lands*

9) Expand opportunity for raccoon and opossum hunting on the J. Robert Gordon Field Trial Area, which is currently limited to open days from the second Monday before Thanksgiving through the Saturday following Thanksgiving, to include all open days from sunrise Monday on or nearest October 15 through the last day of February.

*15A NCAC 10D .0103 Hunting on game lands*

10) Establish Texas Plantation Game Land in Tyrrell County as a Permit Only game land.

*15A NCAC 10D .0103 Hunting on game lands*

### **FISCAL NOTE APPROVAL FOR PROPOSED GAME LAND RULES**

On a motion by Tom Berry and second by Joe Budd, the Commission approved the fiscal note analysis for proposed amendments to and adoption of game lands management rules, presented in **Exhibit J-2**. **Exhibit J-2** is hereby incorporated into the official record of this meeting.

## **BOATING SAFETY RULES AND FISCAL NOTES**

### **Notice of Text – Proposed No Vessel Entry Zone in Public Swimming Area, Jackson County**

Upon a motion by Garry Spence and second by Brian White, the Commission approved **Exhibit K-1**, the recommendation to public Notice of Text for a proposed no-vessel entry zone in a public swimming area at Pines Recreation Area, Lake Glenville in Jackson County. **Exhibit K-1** is hereby incorporated into the official record of this meeting.

### **Approval of Fiscal Note for Proposed No-Vessel Entry Zone, Jackson County**

On a motion by Wes Seegars and second by Nat Harris, the Commission approved **Exhibit K-2**, the fiscal note review for the proposed no-vessel entry zone at Pines Recreation Area on Lake Glenville in Jackson County. **Exhibit K-2** is hereby incorporated into the official record of this meeting.

### **Notice of Text – No Wake Zone in Town of Cedar Point, Carteret County**

Upon a motion by Tommy Fonville and second by Nat Harris, the Commission approved **Exhibit L-1**, the recommendation to publish Notice of Text for a no wake zone in Palmetto Drive Canal in Cedar Point, Carteret County. **Exhibit L-1** is hereby incorporated into the official record of this meeting.

### **Approval of Fiscal Note for Proposed No Wake Zone – Town of Cedar Point, Carteret County**

On a motion by Garry Spence and second by Tim Spear, the Commission approved **Exhibit L-2**, the fiscal note review for a proposed no wake zone in Palmetto Drive Canal in Cedar Point, Carteret County. **Exhibit L-2** is hereby incorporated into the official record of this meeting.

## **ADDITION OF DECEMBER 10, 2015 MEETING OF THE WILDLIFE RESOURCES COMMISSION**

The Commission discussed the need for a December 2015 meeting. A Commissioner Orientation is planned in December. Therefore, on a motion by Mike Johnson and second by Garry Spence the Commission voted to add a Wildlife Resources Commission meeting on Thursday, December 10, 2015. The Commissioner Orientation will be planned on Wednesday, December 9.

## **ADOPTION OF THE 2016 SCHEDULE OF WILDLIFE RESOURCES COMMISSION MEETINGS**

A proposed 2016 schedule of meetings of the North Carolina Wildlife Resources Commission was presented in **Exhibit M**. On a motion by Joe Budd and second by Brian White the Commission adopted the 2016 schedule as follows, with a date change in the October meeting as noted:

**Thursday, February 11, 2016**

**Thursday, April 21, 2016**

**Thursday, July 14, 2016**

**Thursday, August 25, 2016**

**Thursday, October 6, 2016**

**Thursday, December 8, 2016**

**COMMENTS BY THE CHAIRMAN**

Chairman John Litton Clark again welcomed new Commissioners. He thanked staff for their presentations at today's meeting and in committee meetings on October 21. Clark reminded the assembly that there will be a Commission Orientation in December.

**COMMENTS BY THE EXECUTIVE DIRECTOR**

Gordon Myers, *Executive Director*, expressed his deepest appreciation to Mallory Martin, the agency's Chief Deputy Director since 2007. Myers read a Resolution in honor of Mallory Martin, who is retiring November 1, 2015. Upon a motion by Nat Harris and second by Garry Spence, the Resolution was unanimously approved by acclamation. Martin was presented with a retirement certificate and a framed collage in addition to the Resolution. Martin thanked everyone for the Resolution and the framed collage. He noted his appreciation for the support he received from everyone at the agency during his tenure as Chief Deputy Director.

**ADJOURNMENT**

There being no further business, the meeting was adjourned at 11:10 am.

All exhibits are incorporated into the official record of this meeting by reference and are filed with the minutes.

---

John Litton Clark, Chairman

Date

---

Gordon Myers, Executive Director

Date

Summary and Analysis of Agency Operating Cash Balance - Code 14350, 24350, 24351 and 24352

	Oct-14		
<b>Cash Balance July 1</b>		<b>\$ 17,507,785.09</b>	
	<b>2014-2015</b>		
<b>Appropriations</b>	<b>Authorized Budget</b>	<b>Actual</b>	<b>% of</b>
Appropriations	\$ 11,362,948.00	\$ 3,892,404.00	34.26%
<b>Total</b>	<b>\$ 11,362,948.00</b>	<b>\$ 3,892,404.00</b>	<b>34.26%</b>
<b>Receipts</b>			
License Receipts	\$ 18,048,339.00	\$ 9,463,764.90	52.44%
Vessel Receipts	11,310,037.00	3,343,730.00	29.56%
Federal Funds	26,790,957.00	9,722,536.19	36.29%
Publications	345,432.00	358,537.57	103.79%
Professional Services	8,937,075.00	3,540,673.24	39.62%
Agency Reimbursements	2,863,228.00	1,349,553.31	47.13%
Other Receipts	1,154,621.00	741,953.09	64.26%
<b>Total</b>	<b>\$ 69,449,689.00</b>	<b>\$ 28,520,748.30</b>	<b>41.07%</b>
<b>Expenditures</b>			
Administration	\$ 7,886,542.00	\$ 2,868,648.00	36.37%
Enforcement	20,691,706.00	6,948,874.24	33.58%
Education	3,818,730.00	1,192,296.40	31.22%
Inland Fisheries	10,379,044.00	3,238,142.13	31.20%
Management	10,493,054.00	2,485,232.03	23.68%
Engineering Services	18,636,587.00	9,731,956.84	52.22%
Habitat Conservation	-	-	
W/Life Fund Receipts	9,274,360.00	4,133,585.50	44.57%
<b>Total</b>	<b>\$ 81,180,023.00</b>	<b>\$ 30,598,735.14</b>	<b>37.69%</b>
<b>Cash Balance October 31</b>		<b>\$ 19,322,202.25</b>	

	Oct-15		
		<b>\$ 11,302,064.79</b>	
	<b>2015-2016</b>		
<b>Appropriations</b>	<b>Authorized Budget</b>	<b>Actual</b>	<b>% of</b>
Appropriations	\$ -	\$ 3,648,401.00	
<b>Total</b>	<b>\$ -</b>	<b>\$ 3,648,401.00</b>	
<b>Receipts</b>			
License Receipts		\$ 9,609,659.90	
Vessel Receipts		4,166,070.00	
Federal Funds		9,486,851.00	
Publications		323,992.04	
Professional Services		3,158,978.45	
Agency Reimbursements		688,059.48	
Other Receipts		593,981.92	
<b>Total</b>	<b>\$ -</b>	<b>\$ 28,027,592.79</b>	
<b>Expenditures</b>			
Administration		\$ 3,030,490.13	
Enforcement		7,116,976.98	
Education		1,688,710.99	
Inland Fisheries		2,798,465.73	
Management		2,221,897.92	
Engineering Services		8,319,295.41	
Habitat Conservation		295,034.90	
W/Life Fund Receipts		3,535,069.90	
<b>Total</b>	<b>\$ -</b>	<b>\$ 29,005,941.96</b>	
<b>Cash Balance October 31</b>		<b>\$ 13,972,116.62</b>	

**NORTH CAROLINA WILDLIFE RESOURCES COMMISSION**

ENDOWMENT FUND YEAR-TO-DATE

	<u>October 2014</u>	<u>Octoberber 2015</u>
<b>Balance Oct 1</b>	\$ 109,336,386.31	\$ 114,897,425.59
Plus: Revenues from Sales	354,409.59	365,404.39
Return on Investment	642,685.70	409,781.99
	<hr/>	<hr/>
	110,333,481.60	115,672,611.97
Less: Transfers Out	<hr/>	<hr/>
	-	-
<b>Balance Oct 30</b>	<b><u>\$ 110,333,481.60</u></b>	<b><u>\$ 115,672,611.97</u></b>
<b>Market Value</b>	<b>\$ 111,820,594.83</b>	<b>\$ 114,333,306.93</b>

**Endowment Fund Interest**

<u>Sources of Interest Available</u>	<u>Expendable</u>	<u>Non Expendable</u>	<u>Transferred to Operations</u>	<u>Transferred to Capital Projects</u>
<b>ADULT Licenses</b>	\$ 19,769,048.12	\$ -	\$ -	\$ -
<b>INFANT Licenses</b>	-	10,229,392.34	-	-
<b>YOUTH Licenses</b>	-	848,890.09	-	-
<b>Magazine Subscriptions</b>	351,478.56	-	-	-
<b>Contributions - General</b>	820,248.45	-	-	-
<b>Contributions - Diversity</b>	971.10	-	-	-
<b>TOTAL</b>	<b><u>\$ 20,941,746.23</u></b>	<b><u>\$ 11,078,282.43</u></b>	<b><u>\$ -</u></b>	<b><u>\$ -</u></b>

**2015-16 Budgeted Obligated**

<b>Allocation of Endowment Interest - Sportsman Fund</b>	5,095,858.00
<b>Allocation of Endowment Interest - Magazine Fund</b>	271,965.00
	<hr/>
	<b><u>\$ 5,367,823.00</u></b>

**2015-16 Transferred To Date**

<b>To Sportsman Fund</b>	-
<b>To Magazine Fund</b>	-
<b>To Capital Projects</b>	-
	<hr/>
	<b><u>\$ -</u></b>

# EXHIBIT C-1

December 10, 2015

## North Carolina Wildlife Resources Commission Land Acquisition Investigation Form

### -PHASE I: INITIAL INVESTIGATION-

---

**WRC Staff Contact:** Tommy Hughes/Casey Phillips

**Date First Presented to WRC:** December 10, 2015

**Game Land:** Carteret County Game Land

**Tract Name:** Collette Tract

**PIN:** 639803333970200

**Acreage:** 24.93 acre

**County:** Carteret County

**Estimated Value:** Tax value is \$2,400.00 (\$100/ac). The landowner is asking \$ 1,000/ac but is willing to consider fair market value established by an appraisal.

**Property Owner or Representative:** Richard Collette

**Phone:** 252-732-5376

**Email:** NA

**Address:** 1033 Hardesty Farm Road, Newport, NC 28570

**Status:**  High Interest       Moderate Interest       Low Interest       No Interest

**Grant Potential:**  CWMTF

OTHER (explain): Pittman Robertson Land Acquisition Grant, WRC

**Resources Assessment and Biological Benefits (brief):** This 24 acre tract shares approximately 0.45 miles of boundary with the Saltworks tract of the Carteret County Game Land. It is predominately high quality salt marsh, but has ~0.6 miles of sandy beach at the confluence of Core Creek and the Newport River. The tract supports a WRC Wildlife Action Plan Priority habitat and will provide valuable habitat for reptiles, amphibians, waterfowl, shore and wading birds, and furbearers (see attached table).

According to the NC Conservation Planning Tool, 88% of the acreage in this tract has a biodiversity index of 7 out of 10 (1- low-10 high values) and the remaining 12% has a value of 8 out of 10. The Biodiversity/Wildlife Habitat Index prioritizes aquatic and terrestrial habitat, landscape function, and connectivity.

**Additional Comments:** The greatest value of this tract to WRC is that it will allow a 254+ acre burn unit to be incorporated into our prescribed burning program without the establishment of a 0.5 mile long firebreak through high quality salt marsh. This would more than double the acreage we can burn without plow lines on the Saltworks tract and make it logistically feasible to burn using aerial ignition, lowering our overall costs

**5- Year Estimated Stewardship Costs**

Description	Quantity	Unit	Unit/Cost	Total
Roads, Gates and Trails	0	N/A	N/A	\$ 0.00
Prescribed Burning – yr. 1 and 4	24	ac	\$ 30.00	\$ 1,440.00
			<b>Total</b>	<b>\$1,440.00</b>

No revenues are expected from this tract.

**Program Potential:**  Game Land (Carteret County)  Wildlife Conservation Area  
 Fishing Access Area  None

**Potential Source(s) of Stewardship Funds (indicate federal:state match rates):** Pittman-Robertson Federal Assistance Grant (75% federal: 25% state)

**Relative Priority Evaluation Score (attach worksheet):**

**Recommendation:**  Pursue Acquisition  Defer  Do not Pursue Acquisition

**Map Attached:**  Yes  No

Priority species associated with estuarine communities:

Group	Scientific Name	Common Name	State Status (Federal Status)
Birds	<i>Ammodramus caudacutus</i>	Saltmarsh Sharp-tailed Sparrow	
	<i>Ammodramus nelsoni</i>	Nelson's Sharp-tailed Sparrow	
	<i>Asio flammeus</i>	Short-eared Owl	
	<i>Botaurus lentiginosus</i>	American Bittern	SR
	<i>Calidris alba</i>	Sanderling	
	<i>Calidris canutus</i>	Red Knot	
	<i>Charadrius melodus</i>	Piping Plover	T (T)
	<i>Charadrius wilsonia</i>	Wilson's Plover	SR
	<i>Circus cyaneus</i>	Northern Harrier	SR
	<i>Cistothorus platensis</i>	Sedge Wren	
	<i>Coturnicops noveboracensis</i>	Yellow Rail	SR
	<i>Egretta caerulea</i>	Little Blue Heron	SC
	<i>Egretta thula</i>	Snowy Egret	SC
	<i>Egretta tricolor</i>	Tricolored Heron	SC
	<i>Falco peregrinus</i>	Peregrine Falcon	E
	<i>Haematopus palliatus</i>	American Oystercatcher	SR
	<i>Haliaeetus leucocephalus</i>	Bald Eagle	T (T)
	<i>Himantopus mexicanus</i>	Black-necked Stilt	SR
	<i>Ixobrychus exilis</i>	Least Bittern	
	<i>Laterallus jamaicensis</i>	Black Rail	SR
	<i>Mycteria americana</i>	Wood Stork	E (E)
	<i>Nyctanassa violacea</i>	Yellow-crowned Night-heron	
	<i>Pelecanus occidentalis</i>	Brown Pelican	SR
	<i>Plegadis falcinellus</i>	Glossy Ibis	SC
	<i>Porzana carolina</i>	Sora	
	<i>Rallus elegans</i>	King Rail	
	<i>Rallus limicola</i>	Virginia Rail	
	<i>Rynchops niger</i>	Black Skimmer	SC
	<i>Sterna antillarum</i>	Least Tern	SC
	<i>Sterna caspia</i>	Caspian Tern	SR
	<i>Sterna hirundo</i>	Common Tern	SC
<i>Sterna nilotica</i>	Gull-billed Tern	T	
Mammals	<i>Cryptotis parva</i>	Least Shrew	
	<i>Sylvilagus palustris</i>	Marsh Rabbit	
	<i>Trichechus manatus</i>	Manatee	E (E)
Reptiles	<i>Caretta caretta</i>	Loggerhead Sea Turtle	T (T)
	<i>Chelonia mydas</i>	Green Sea Turtle	T (T)
	<i>Eretmochelys imbricata imbricata</i>	Atlantic Hawksbill Sea Turtle	E (E)
	<i>Lampropeltis getula getula</i>	Eastern Kingsnake	
	<i>Lampropeltis getula sticticeps</i>	Outer Banks Kingsnake	SC
	<i>Lepidochelys kempii</i>	Kemp's Ridley Sea Turtle	E (E)
	<i>Malaclemys terrapin</i>	Diamond-backed Terrapin	SC
	<i>Nerodia sipedon williamengelsi</i>	Carolina Watersnake	SC
	<i>Thamnophis sauricus sauricus</i>	Common Ribbonsnake	



**WORKSHEET**  
**Relative Priority Evaluation for Conservation Lands**

Tract Name (Carteret County GL) Collette Tract (Carteret County)

Criterion	Score (1-5) 5=Excellent 1=Poor
1. Augments existing protected lands by addressing an inholding or adjacent tract, provides key access, buffers or connects existing WRC-managed lands.	<u>5</u>
2. Represents good hunting, fishing, wildlife viewing, and other resource-based recreational opportunities.	<u>5</u>
3. No conflicting surrounding land uses.	<u>5</u>
4. Serves as a wildlife corridor between areas already protected for conservation purposes and provides connectivity to priority Wildlife Action Plan habitats.	<u>5</u>
5. Augments land conservation efforts on a landscape scale by providing nuclei (“anchors”) for regional conservation efforts, corridors, key linkages between conservation areas, or keystone tracts.	<u>5</u>
6. Fills a need identified by the Wildlife Action Plan, such as critical, rare or unique habitats; natural heritage elements; or significant aquatic/terrestrial resources.	<u>5</u>
7. Is this an area in which we would like to establish a new game land, wildlife conservation area, or fishing access?	<u>NA</u>
8. Is it large enough to be a new game land, and if not, are there possibilities for expansion (goal 3,000-5,000 acre minimum)?	<u>NA</u>
9. Is area adequate for fishing access development with suitable parking, and if not, are there possibilities for expansion?	<u>NA</u>
<b>TOTAL SCORE</b>	<u><u>30</u></u>

# Collette Tract Carteret County GL Carteret County 25 Acres

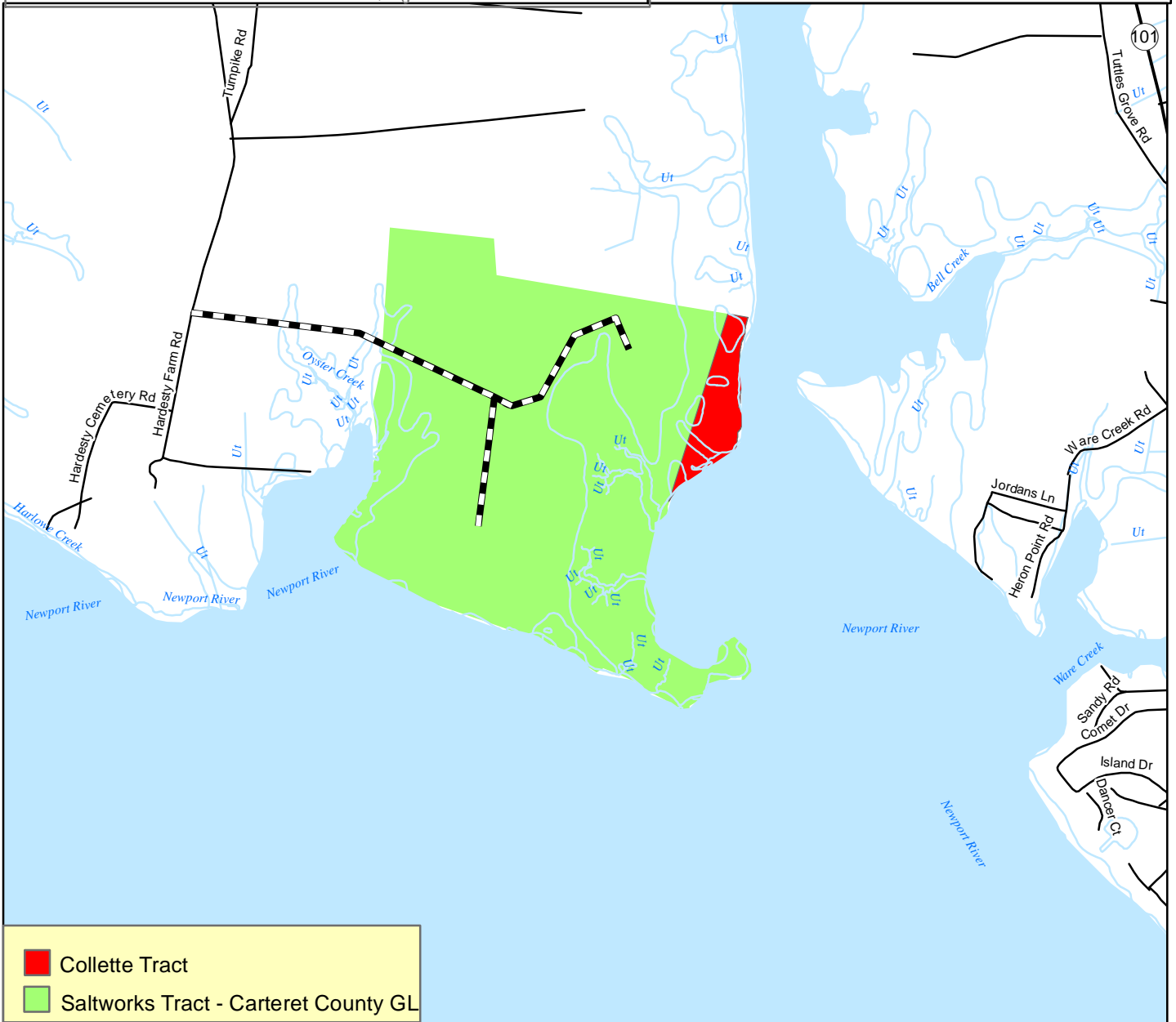
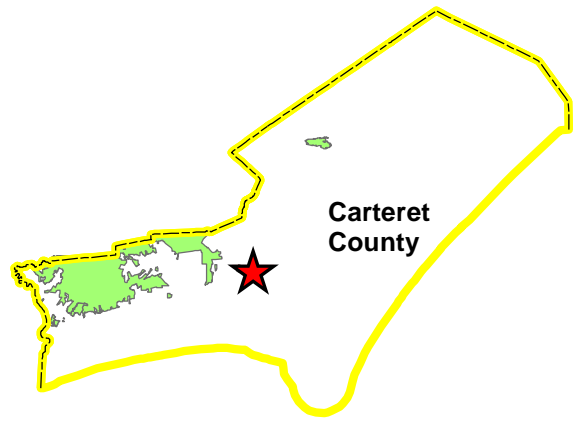

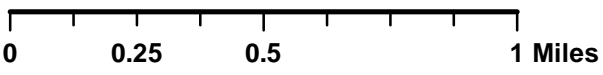

November 13, 2015

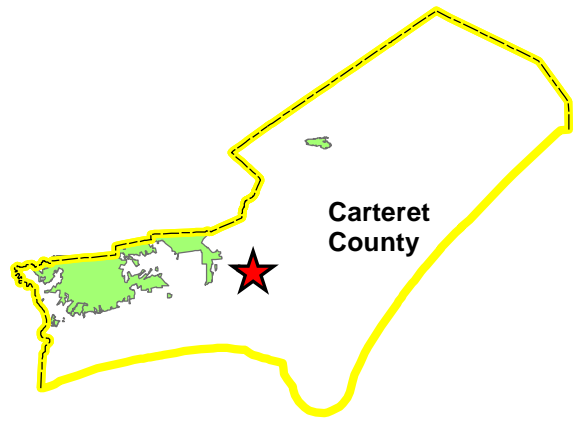

**Collette Tract  
Carteret County GL  
Carteret County  
25 Acres**



-  Collette Tract
-  Saltworks Tract - Carteret County GL



November 13, 2015

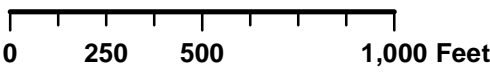

# EXHIBIT C-2

December 10, 2015

## North Carolina Wildlife Resources Commission Land Acquisition Investigation Form

**-PHASE I: INITIAL INVESTIGATION-**

---

**WRC Staff Contact:** Kip Hollifield

**Date First Presented to WRC:** December 10, 2015

**Game Land:** Three Top Mountain Game Land

**Tract Name:** Lambb Lot, (Lot 256 on plat)

**PIN:** Not available (see "additional comments" below)

**Acreage:** +/- 0.75 acre

**County:** Ashe

**Estimated Value:** approximately \$3,000 (pending appraisal)

**Property Owner or Representative:** Reginald Lambb

**Phone:** 813-494-7358

**Email:** NA

**Address:** 5211 Clover Mist Drive  
Apollo Beach, FL 33572

**Status:**  High Interest       Moderate Interest       Low Interest       No Interest

**Grant Potential:**  CWMTF

OTHER (explain): WRC funds

**Resources Assessment and Biological Benefits (brief):** Resources are typical of the Three Top Mountain area, with Appalachian oak forest predominant. The lot is part of the nationally significant Three Top Mountain Natural Heritage Area. Three Top Mountain GL was purchased in 1993 as a failed development. Unfortunately a number of lots had already been sold in this failed development. WRC has made it a priority to purchase private lots that are embedded in the main GL property or those that reduce property fragmentation around the GL perimeter. The main interest in acquisition of the Lambb Lot is to solidify WRC ownership and remove a private inholding within the game land. WRC acquisition will also alleviate the potential for a future request for landowner access across the game land to this lot. If acquired, the main management objective will be adding this acreage to the game land.

Common game species found on Three Top Mtn. Game Land include wild turkey, black bear, white-tailed deer, ruffed grouse, raccoon, and gray squirrel. WAP priority species likely found as either permanent residents or transients are indicated in the table below.

Yellow-bellied sapsucker	<i>Sphyrapicus varius</i>
Eastern wood-pewee	<i>Contopus virens</i>
Northern flicker	<i>Colaptes auratus</i>
Brown creeper	<i>Certhia americana</i>
Canada warbler	<i>Cardellina canadensis</i>
Rose-breasted grosbeak	<i>Pheucticus ludovicianus</i>
Wood thrush	<i>Hylocichla mustelina</i>
Sharp-shinned hawk	<i>Accipiter striatus</i>
Weller's salamander	<i>Plethodon welleri</i>
Northern pigmy salamander	<i>Desmognathus wrighti</i>
Southern ravine salamander	<i>Plethodon richmondi</i>
Southern pygmy shrew	<i>Sorex hoyi winnemana</i>

**Additional Comments:**

The Lambb lot is not shown in the online Ashe Co. tax maps nor is the deed available in an online search from the Ashe Co. Register of Deeds Office. This circumstance is not unusual, as not all of the lots and correct ownership for this failed development is available from online tools provided by Ashe Co. If approved for acquisition, Mr. Lambb is aware that verification of ownership will be required.

The shapefile provided is an approximation of the lot location based on comparison of the development plat with 1993 aerial imagery.

Preliminary estimate of five-year stewardship expenditures is limited to surveying 750 feet of property line at approx. \$1.25/foot for a total estimated cost of \$937.50.

No short-term revenue is projected from the tract

**Program Potential:**  Game Land (Three Top)  Wildlife Conservation Area  
 Fishing Access Area  None

**Potential Source(s) of Stewardship Funds (indicate federal:state match rates):** Pittman-Robertson Federal Assistance Grant (75% federal: 25% state)

**Relative Priority Evaluation Score (attach worksheet):**

**Recommendation:**  Pursue Acquisition  Defer  Do not Pursue Acquisition

**Map Attached:**  Yes  No

**WORKSHEET**  
**Five Year Stewardship Costs and Revenue Projections**  
**(Five Years Post Acquisition)**

STEWARDSHIP					
Estimated Stewardship Expenditures					
Tract Name	Activity	Quantity	Unit	Unit Cost	Total Cost
Lambb Lot	Survey	750	Ft.	\$1.25	\$937.50
<b>Total</b>					<b>\$937.50</b>
<i>Insert additional rows in table as needed</i>					

REVENUE					
Estimated Revenue Projections					
Tract Name	Source	Quantity	Unit	Unit Revenue	Total Revenue
					\$ -
<b>Total</b>					<b>\$ -</b>
<i>Insert additional rows in table as needed</i>					



**WORKSHEET**  
**Relative Priority Evaluation for Conservation Lands**

Tract Name (Three Top GL)    Lambb Lot (Ashe County)

Criterion	Score (1-5) 5=Excellent 1=Poor
1. Augments existing protected lands by addressing an inholding or adjacent tract, provides key access, buffers or connects existing WRC-managed lands.	<u>5</u>
2. Represents good hunting, fishing, wildlife viewing, and other resource-based recreational opportunities.	<u>4</u>
3. No conflicting surrounding land uses.	<u>5</u>
4. Serves as a wildlife corridor between areas already protected for conservation purposes and provides connectivity to priority Wildlife Action Plan habitats.	<u>5</u>
5. Augments land conservation efforts on a landscape scale by providing nuclei (“anchors”) for regional conservation efforts, corridors, key linkages between conservation areas, or keystone tracts.	<u>5</u>
6. Fills a need identified by the Wildlife Action Plan, such as critical, rare or unique habitats; natural heritage elements; or significant aquatic/terrestrial resources.	<u>5</u>
7. Is this an area in which we would like to establish a new game land, wildlife conservation area, or fishing access?	<u>NA</u>
8. Is it large enough to be a new game land, and if not, are there possibilities for expansion (goal 3,000-5,000 acre minimum)?	<u>NA</u>
9. Is area adequate for fishing access development with suitable parking, and if not, are there possibilities for expansion?	<u>NA</u>
<b>TOTAL SCORE</b>	<u><u>29</u></u>

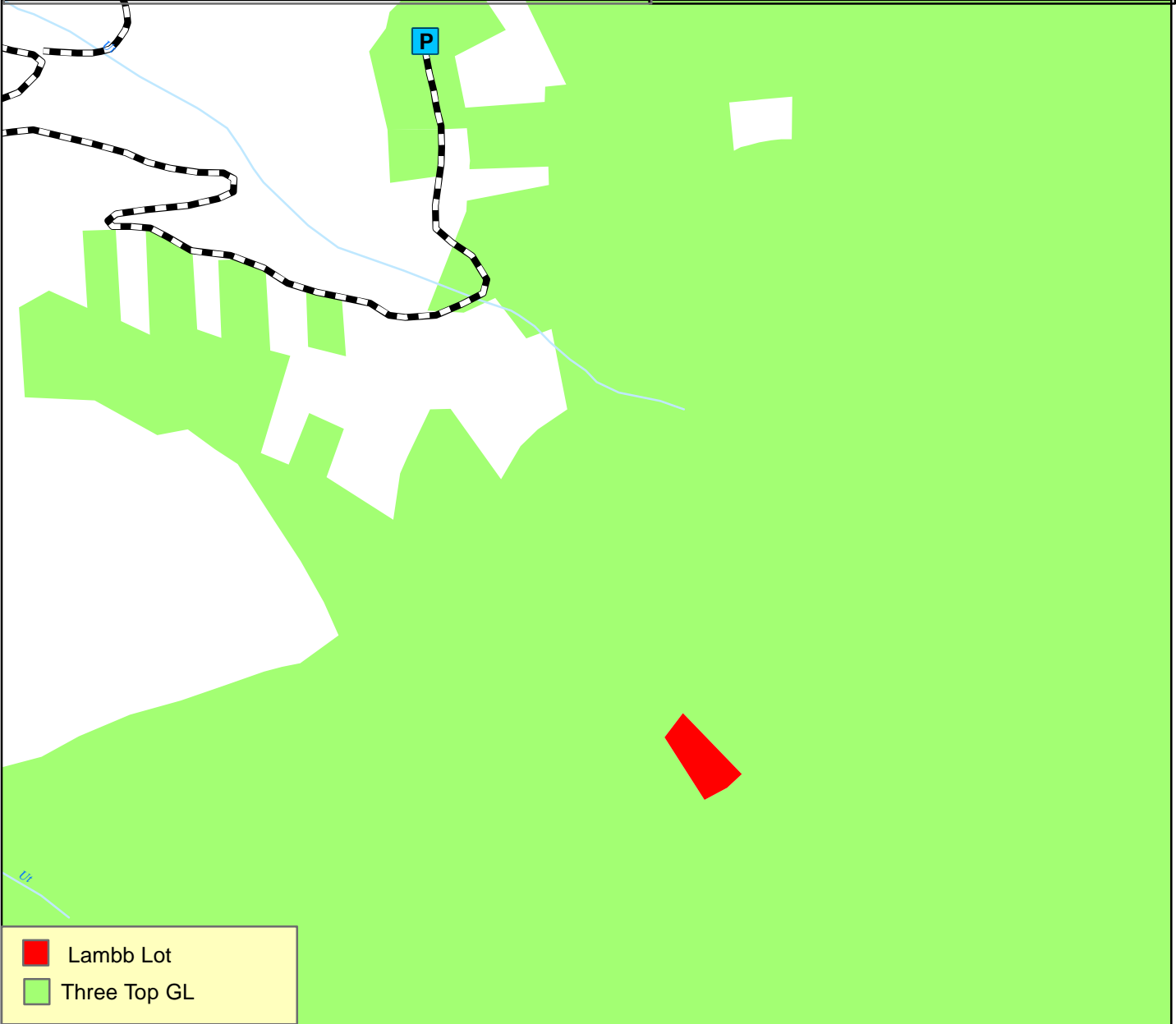
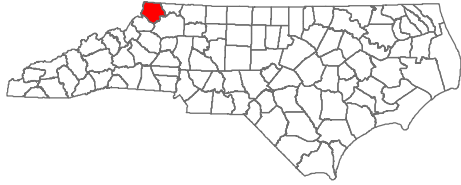
**Lambb Lot 256  
Three Top Game Land  
Ashe County  
0.75 Acres**



-  Lambb Lot
-  Three Top GL



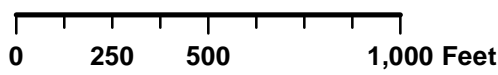

November 13, 2015





**Lambb Lot 256  
Three Top Game Land  
Ashe County  
0.75 Acres**



-  Lambb Lot
-  Three Top GL



November 13, 2015

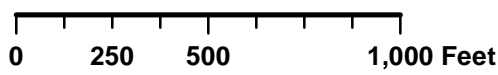

# EXHIBIT C-3

December 10, 2015

## North Carolina Wildlife Resources Commission Land Acquisition Investigation Form

### -PHASE I: INITIAL INVESTIGATION-

---

**WRC Staff Contact:** Tommy Hughes

**Date First Presented to WRC:** December 10, 2015

**Tract Name:** Little Macedonia

**Acreage:** 261.350

**County:** Brunswick

**Pin Number:** 1510-0-031

**Estimated Value:** \$ 530,000 asking price. Realtor advises owner is willing to sale below fair market value. Brunswick County indicates a total tax value of \$1,954,900. A 2011 appraisal provided by the realtor values the property at \$970,000.

**Property Owner or Representative:** Linda Stephens (Realtor)

**Phone:** (W) 910-231-0640    **Email:** lindastephens1948@atmc.net

**Address:** Coldwell Banker Sea Coast Advantage Holden Beach  
3247 Holden Beach Road SW  
Supply, NC 28462

**Status:**  High Interest     Moderate Interest     Low Interest     No Interest

**Grant Potential:**  CWMTF

OTHER (explain): Pittman Robertson Land Acquisition Grant, WRC;

**Resources Assessment and Biological Benefits (brief):** The Little Macedonia Tract is located in Brunswick County, approximately 2.41 miles northwest of Supply, 8.6 miles southwest of the temporary Bolivia Depot and 3.2 miles southeast of the state-owned Juniper Creek Game Land. The tract represents an excellent location to construct a depot facility for the Bolivia crew.

The site is 261 acres and contains two agricultural fields, a small pond and cutover woodlands. The site contains sandy well drained soils that should be suitable for depot construction. The site does not support county water or sewer, but judging from homes in the area, it should support a suitable well and septic system.

In addition to a depot site, the tract is large enough to potentially allow development of a dove field and could provide limited deer and small game hunting. The tract is bounded on the east south and west by a small creek and pocosin and contains considerable topography. The property is primarily uplands that have been cutover. Currently, there is no marketable timber on the property.

The tract supports NCWRC Wildlife Action Plan Priority habitats (early successional with the potential to restore dry longleaf pine) and species and will provide valuable habitat for reptiles, amphibians, neo-tropical migrants, white-tailed deer, wild turkey, small game, and furbearers.

Access to the property is via a state road (Little Macedonia). The interior of the property contains a network of unimproved sandy roads that provide administrative access and with improvement could provide public access points.

Based upon data found in the NC Conservation Planning Tool, the Little Macedonia Tract's Biodiversity index ranges from 0-4. Approximately 10% of the site is ranked as a 1 and 10% ranked as a 4 with the balance of the tract being assessed as a 0 (1- low-10 high values). The Biodiversity/Wildlife Habitat Index prioritizes aquatic and terrestrial habitat, landscape function, and connectivity.

**Additional Comments:** Suitable, reasonably priced land for depot construction in Brunswick County is difficult to locate. This tract is located close to all areas the Bolivia crew currently services. The temporary depot the Bolivia crew is working out of is currently adequate but its future is uncertain. This tract offers an opportunity to develop a permanent location from which this crew can work.

Although additional evaluation is necessary to confirm, the site may also represent potential to develop a shooting range.

**Program Potential:**  Game Land (Juniper Creek)  Wildlife Conservation Area  
 Fishing Access Area  Potential Depot Site

**Potential Source(s) of Stewardship Funds (indicate federal:state match rates):** Pittman-Robertson Federal Assistance Grant (75% federal: 25% state)

**Relative Priority Evaluation Score (attach worksheet):**

**Recommendation:**  Pursue Acquisition  Defer  Do not Pursue Acquisition

**Map Attached:**  Yes  No

**WORKSHEET**  
**Relative Priority Evaluation for Conservation Lands**

Tract Name Little Macedonia Tract (Brunswick County)

Criterion Score (1-5)  
5=Excellent 1=Poor

- |   |    |
|---|----|
| 1. Augments existing protected lands by addressing an inholding or adjacent tract, provides key access, buffers or connects existing WRC-managed lands.   | 3  |
| 2. Represents good hunting, fishing, wildlife viewing, and other resource-based recreational opportunities.   | 5  |
| 3. No conflicting surrounding land uses.  | 5  |
| 4. Serves as a wildlife corridor between areas already protected for conservation purposes and provides connectivity to priority Wildlife Action Plan habitats.                                       | 1  |
| 5. Augments land conservation efforts on a landscape scale by providing nuclei (“anchors”) for regional conservation efforts, corridors, key linkages between conservation areas, or keystone tracts. | 3  |
| 6. Fills a need identified by the Wildlife Action Plan, such as critical, rare or unique habitats; natural heritage elements; or significant aquatic/terrestrial resources.                           | 5  |
| 7. Is this an area in which we would like to establish a new game land, wildlife conservation area, or fishing access?  | NA |
| 8. Is it large enough to be a new game land, and if not, are there possibilities for expansion (goal 3,000-5,000 acre minimum)?   | NA |
| 9. Is area adequate for fishing access development with suitable parking, and if not, are there possibilities for expansion?  | No |

**TOTAL SCORE** 22

## Little Macedonia Tract

### 5- Year Estimated Stewardship Costs

Description	Quantity	Unit	Unit/Cost	Total (5-yrs)
Improve Road System – yr. 1	1	mi	\$ 50,000	\$ 50,000
Maintain Road System- yr 2-5	1	ea	\$ 2,500	\$ 10,000
Establish Gate – yr. 1	7	ea	\$ 1,500	\$ 10,500
Maintain Gate – yr. 2 - 5	7	ea	\$ 200	\$ 5,600
Boundary Establishment – yr. 1	4	mi	\$ 1,500	\$ 6,000
Boundary Maintenance- yr. 4	4	mi	\$ 500	\$ 2,000
Administer Co-Op Farm Lease	1	ea	\$ 1,000	\$ 5,000
Depot Construction	1	Ea	\$ 750,000	\$ 750,000
			<b>Total</b>	<b>\$ 839,100</b>

### 5-Year Anticipated Revenue

			Value	Total
Farm Co-Op Lease-If we decide to lease rather than developing a dove field.	20	ac	\$ 40	\$ 800
			<b>Total</b>	<b>\$ 800</b>

**Priority species associated with coastal plain early successional habitat:**

<b>Group</b>	<b>Scientific Name</b>	<b>Common Name</b>	<b>State Status (Federal Status)</b>
Birds	<i>Aimophila aestivalis</i>	Bachman's Sparrow	SC
	<i>Ammodramus henslowii</i>	Henslow's Sparrow	SR
	<i>Ammodramus savannarum</i>	Grasshopper Sparrow	
	<i>Asio flammeus</i>	Short-eared Owl	
	<i>Caprimulgus carolinensis</i>	Chuck-will's-widow	
	<i>Caprimulgus vociferus</i>	Whip-poor-will	
	<i>Chondestes grammacus</i>	Lark Sparrow	SR
	<i>Chordeiles minor</i>	Common Nighthawk	
	<i>Circus cyaneus</i>	Northern Harrier	SR
	<i>Cistothorus platensis</i>	Sedge Wren	
	<i>Colinus virginianus</i>	Northern Bobwhite	
	<i>Dendroica discolor</i>	Prairie Warbler	
	<i>Falco sparverius</i>	American Kestrel	
	<i>Icterus spurius</i>	Orchard Oriole	
	<i>Lanius ludovicianus</i>	Loggerhead Shrike	SC
	<i>Passerina ciris</i>	Eastern Painted Bunting	
	<i>Scolopax minor</i>	American Woodcock	
	<i>Spizella pusilla</i>	Field Sparrow	
	<i>Sturnella magna</i>	Eastern Meadowlark	
	<i>Tyrannus tyrannus</i>	Eastern Kingbird	
<i>Tyto alba</i>	Barn Owl		
Mammals	<i>Condylura cristata</i>	Star-nosed Mole	SC
	<i>Cryptotis parva</i>	Least Shrew	
	<i>Microtus pennsylvanicus</i>	Meadow Vole	
	<i>Mustela frenata</i>	Long-tailed Weasel	
	<i>Scalopus aquaticus</i>	Eastern Mole	
	<i>Synaptomys cooperi helaletes</i>	Southern Bog Lemming	
Reptiles	<i>Crotalus adamanteus</i>	Eastern Diamond-backed Rattlesnake	E
	<i>Lampropeltis calligaster rhombomaculata</i>	Mole Kingsnake	
	<i>Lampropeltis getula getula</i>	Eastern Kingsnake	
	<i>Masticophis flagellum</i>	Eastern Coachwhip	SR
	<i>Ophisaurus attenuatus longicaudus</i>	Eastern Slender Glass Lizard	
	<i>Pituophis melanoleucus melanoleucus</i>	Northern Pinesnake	SC
	<i>Terrapene carolina</i>	Eastern Box Turtle	



## Potential Restoration

### Priority species associated with coastal plain dry longleaf pine habitats:

Group	Scientific Name	Common Name	State Status (Federal Status)
Birds	<i>Aimophila aestivalis</i>	Bachman's Sparrow	SC
	<i>Ammodramus henslowii</i>	Henslow's Sparrow	SR
	<i>Caprimulgus carolinensis</i>	Chuck-will's-widow	
	<i>Caprimulgus vociferus</i>	Whip-poor-will	
	<i>Colaptes auratus</i>	Northern Flicker	
	<i>Colinus virginianus</i>	Northern Bobwhite	
	<i>Contopus virens</i>	Eastern Wood-pewee	
	<i>Dendroica discolor</i>	Prairie Warbler	
	<i>Falco sparverius</i>	American Kestrel	
	<i>Melanerpes erythrocephalus</i>	Red-headed Woodpecker	
	<i>Picoides borealis</i>	Red-cockaded Woodpecker	E (E)
	<i>Sitta pusilla</i>	Brown-headed Nuthatch	
Mammals	<i>Lasiurus seminolus</i>	Seminole Bat	
	<i>Sciurus niger</i>	Eastern Fox Squirrel	SR
Amphibians	<i>Ambystoma tigrinum</i>	Eastern Tiger Salamander	T
	<i>Bufo quercicus</i>	Oak Toad	SR
	<i>Hyla andersonii</i>	Pine Barrens Treefrog	
	<i>Hyla gratiosa</i>	Barking Treefrog	
	<i>Plethodon glutinosus sensustricto</i>	Northern Slimy Salamander	
	<i>Pseudacris ornata</i>	Ornate Chorus Frog	SR
	<i>Rana capito</i>	Carolina Gopher Frog	T
	<i>Scaphiopus holbrookii</i>	Eastern Spadefoot	
Reptiles	<i>Cemophora coccinea copei</i>	Northern Scarletsnake	
	<i>Crotalus adamanteus</i>	Eastern Diamondback Rattlesnake	E
	<i>Crotalus horridus</i>	Timber (Canebrake) Rattlesnake	SC
	<i>Elaphe guttata</i>	Corn Snake	
	<i>Heterodon platirhinos</i>	Eastern Hog-nosed Snake	
	<i>Heterodon simus</i>	Southern Hog-nosed Snake	SC
	<i>Lampropeltis calligaster rhombomaculata</i>	Mole Kingsnake	
	<i>Lampropeltis triangulum elapsoides</i>	Scarlet Kingsnake	
	<i>Masticophis flagellum</i>	Eastern Coachwhip	SR
	<i>Micrurus fulvius</i>	Eastern Coral Snake	E
	<i>Ophisaurus attenuatus longicaudus</i>	Eastern Slender Glass Lizard	
	<i>Pituophis melanoleucus melanoleucus</i>	Northern Pinesnake	SC
	<i>Sistrurus miliarius</i>	Pigmy Rattlesnake	SC
	<i>Tantilla coronata</i>	Southeastern Crowned Snake	

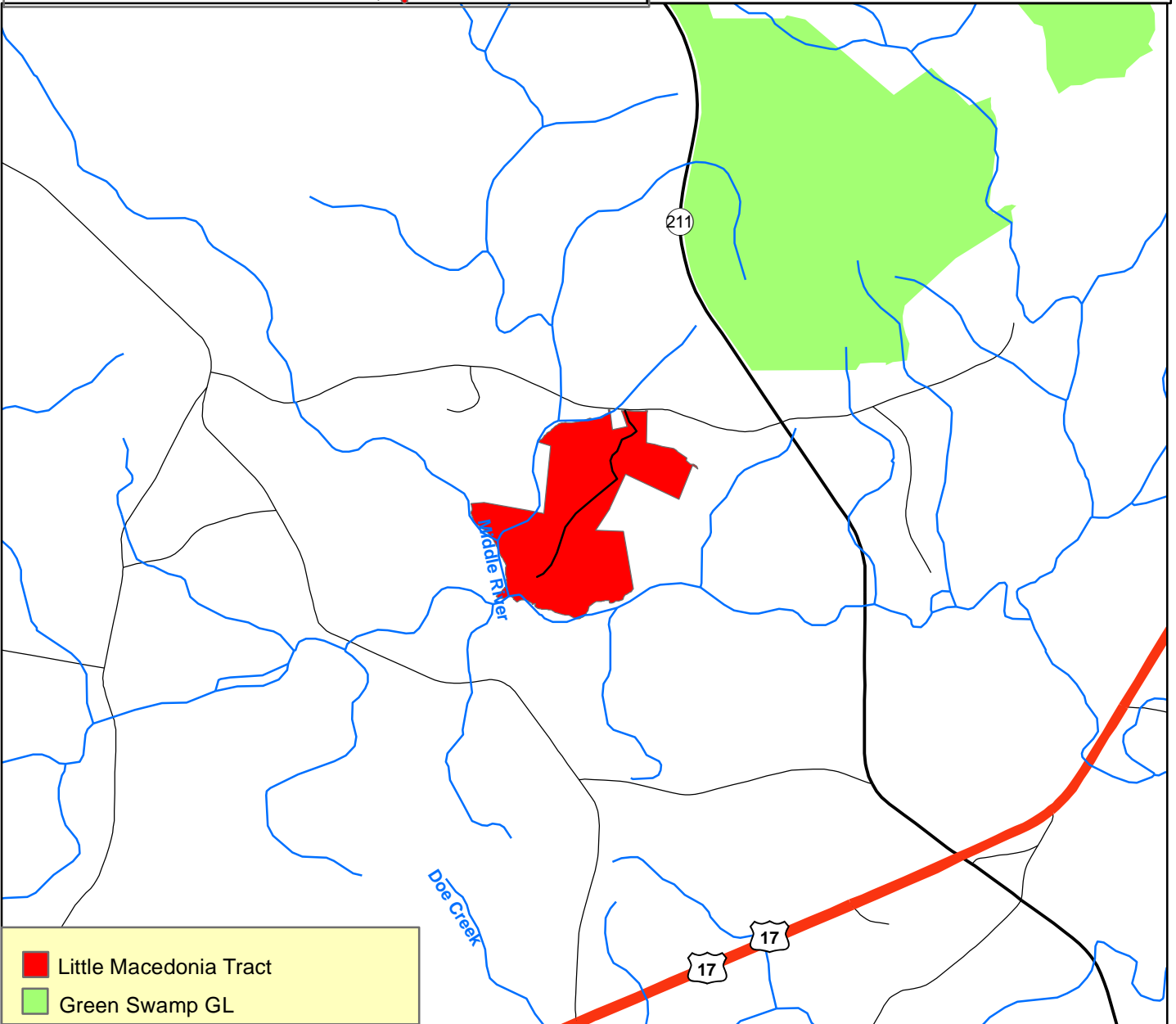
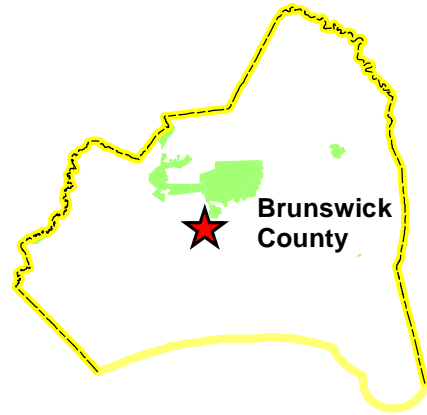
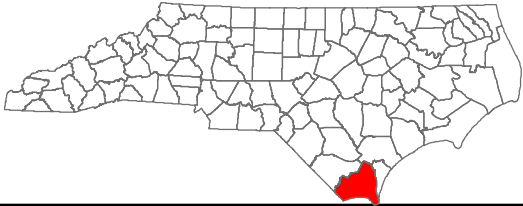
# Little Macedonia Tract Potential Depot Site Brunswick County 261 Acres



-  Little Macedonia Tract
-  Green Swamp GL



November 13, 2015

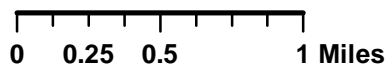



**Little Macedonia Tract  
Potential Depot Site  
Brunswick County  
261 Acres**

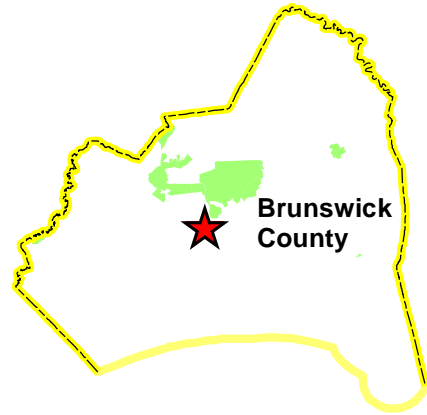
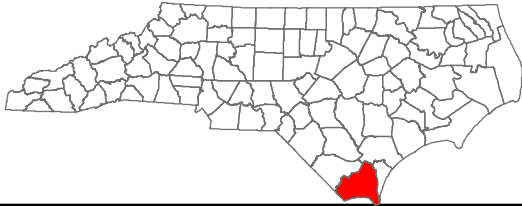

November 13, 2015

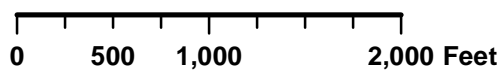

# EXHIBIT C-4

December 10, 2015

## North Carolina Wildlife Resources Commission Land Acquisition Investigation Form

### -PHASE I: INITIAL INVESTIGATION-

---

**WRC Staff Contact:** Andrew Mynatt

**Date First Presented to WRC:** December 10, 2015.

**Tract Name:** Pontiac Plywood

**PIN:** Unable to determine from county parcel data

**Acreage:** 19

**County:** Warren

**Estimated Value:** \$38,000 (\$2,000/acre); Owner asking \$57,000 (\$3,000/acre)

**Property Owner or Representative:** Pontiac Plywood Inc. c/o Hunter Stone

**Phone:** (252) 230-9068

**Address:** 3204 Nash Street - Suite C, Wilson, NC 27896

**Status:**  High Interest       Moderate Interest       Low Interest       No Interest

**Grant Potential:**  CWTF

OTHER (explain): Pittman Robertson Land Acquisition Grant, WRC

**Resources Assessment and Biological Benefits (brief):** These three small tracts are adjacent to the Odell Tract of Embro Game Land. The owner has approached WRC about accessing these three tracts to conduct future timber harvests. Access to these tracts (deeded or “negotiated”) would be through WRC game land property on existing GL roads, across WRC game land property on old public roads (that no longer exist) or “through the woods” on WRC game land property (roads that would need to be built). In lieu of those options, the owner would prefer to sell the properties to the buyer that inherently has the best existing access. WRC has the best inherent access to these three properties. Acquisition of these tracts will eliminate the encumbrance of access that WRC currently bears for these three tracts and will create a more regular shaped boundary line on this portion of the game land.

A final timber harvest was conducted on these tracts in 2000. These areas were replanted in 2001 to loblolly pine at a rate of approximately 400 trees per acre. Although some seedling mortality was experienced on the lower and wet reaches of the tracts, a viable, mostly pine stand with some mixed hardwood areas exists today. No structures exist on the property. Access to the tracts would be on existing game land roads and trails.

Four hundred feet of an unnamed tributary crosses the southeast corner of Tract 1. This tributary drains into Reedy Creek through existing game land property to the south. Acquisition of these properties will protect additional significant aquatic habitat resources that occur in the areas downstream of these tracts.

Many state and federally listed species occur in the aquatic habitats found in this Upper Tar region. The protection of floodplains by game lands in this region protect water quality of the creeks and thus greatly benefit populations of numerous species in these waters.

**Additional Comments:**

Preliminary estimates of five-year stewardship expenditures include establishing and/or maintaining 1.5 miles of property boundary for a total estimated cost of approx. \$350.

Short-term revenue of approx. \$7,500 is expected from thinning 15 acres of loblolly pine (\$500/ac).

- Program Potential:**      Game Land (Embryo)                                  Wildlife Conservation Area  
    Fishing Access Area      None

**Potential Source(s) of Stewardship Funds (indicate federal: state match rates):** Pittman-Robertson Federal Assistance Grant (75% federal: 25% state)

**Relative Priority Evaluation Score (attach worksheet):**

- Recommendation:**    Pursue Acquisition              Defer                      Do not Pursue Acquisition

- Map Attached:**    Yes                      No

**Pontiac Plywood Tracts (Warren County) - Priority Species**

SCIENTIFIC NAME	COMMON NAME	FED LISTED	STATE LISTED
<b>AMPHIBIANS</b>			
<i>Plethodon glutinosus</i>	Slimy Salamander		
<i>Hemidactylium scutatum</i>	Four-toed Salamander		SC
<i>Siren lacertina</i>	Greater Siren		
<i>Hyla versicolor</i>	Gray Treefrog		SR
<b>BIRDS</b>			
<i>Lophodytes cucullatus</i>	Hooded Merganser		
<i>Ixobrychus exilis</i>	Least Bittern		SC
<i>Accipiter striatus</i>	Sharp-shinned Hawk		SR
<i>Falco sparverius</i>	American Kestrel		
<i>Tyto alba</i>	Barn Owl		SR
<i>Lanius ludovicianus</i>	Loggerhead Shrike		SC
<i>Aimophila aestivalis</i>	Bachman's Sparrow		SC
<i>Ammodramus savannarum</i>	Grasshopper Sparrow		
<i>Spiza americana</i>	Dickcissel		
<b>MAMMALS</b>			
<i>Lasiurus cinereus</i>	Hoary Bat		
<i>Myotis septentrionalis</i>	Northern Myotis		
<i>Zapus hudsonius</i>	Meadow Jumping Mouse		
<b>REPTILES</b>			
<i>Clemmys guttata</i>	Spotted Turtle		
<i>Ophisaurus attenuatus</i>	Slender Glass Lizard		SR
<i>Cemophora coccinea</i>	Scarlet Snake		
<i>Lampropeltis triangulum elapsoides</i>	Scarlet Kingsnake		
<i>Lampropeltis triangulum triangulum</i>	Eastern Milk Snake		
<i>Virginia valeriae</i>	Smooth Earth Snake		

**WORKSHEET**  
**Five Year Stewardship Costs and Revenue Projections**  
**(Five Years Post Acquisition)**

<b>STEWARDSHIP</b>					
<b>Estimated Stewardship Expenditures</b>					
<b>Tract Name</b>	<b>Activity</b>	<b>Quantity</b>	<b>Unit</b>	<b>Unit Cost</b>	<b>Total Cost</b>
<b>Pontiac Plywood</b>	Establish Boundary	1.0	mi.	270.00	\$270.00
	Maintain Boundary	0.5	mi.	135.00	\$ 67.50
	<b>Total</b>				<b>\$ 337.50</b>
<i>Boundary maintenance required every 4 to 5 years</i>					

<b>REVENUE</b>					
<b>Estimated Revenue Projections</b>					
<b>Tract Name</b>	<b>Source</b>	<b>Quantity</b>	<b>Unit</b>	<b>Unit Revenue</b>	<b>Total Revenue</b>
<b>Pontiac Plywood</b>	Timber Harvest (1 <sup>st</sup> thinning 2020)	15	ac.	\$500.00	\$7,500.00
	<b>Total</b>				<b>\$7,500.00</b>

## WORKSHEET

### Relative Priority Evaluation for Conservation Lands

Tract Name (Embro GL) Pontiac Plywood Tract (Warren County)

Criterion Score (1-5)  
5=Excellent 1=Poor

- |   |           |
|---|-----------|
| 1. Augments existing protected lands by addressing an inholding or adjacent tract, provides key access, buffers or connects existing WRC-managed lands.   | 5         |
| 2. Represents good hunting, fishing, wildlife viewing, and other resource-based recreational opportunities.   | 5         |
| 3. No conflicting surrounding land uses.  | 5         |
| 4. Serves as a wildlife corridor between areas already protected for conservation purposes and provides connectivity to priority Wildlife Action Plan habitats.                                       | 3         |
| 5. Augments land conservation efforts on a landscape scale by providing nuclei (“anchors”) for regional conservation efforts, corridors, key linkages between conservation areas, or keystone tracts. | 3         |
| 6. Fills a need identified by the Wildlife Action Plan, such as critical, rare or unique habitats; natural heritage elements; or significant aquatic/terrestrial resources.                           | 5         |
| 7. Is this an area in which we would like to establish a new game land, wildlife conservation area, or fishing access?  | No        |
| 8. Is it large enough to be a new game land, and if not, are there possibilities for expansion (goal 3,000-5,000 acres minimum)?  | NA        |
| 9. Is area adequate for fishing access development with suitable parking, and if not, are there possibilities for expansion?  | NA        |
| <b>TOTAL SCORE</b>  | <b>26</b> |

**Pontiac Plywood Tracts  
Embro GL  
Warren County  
19 Acres**

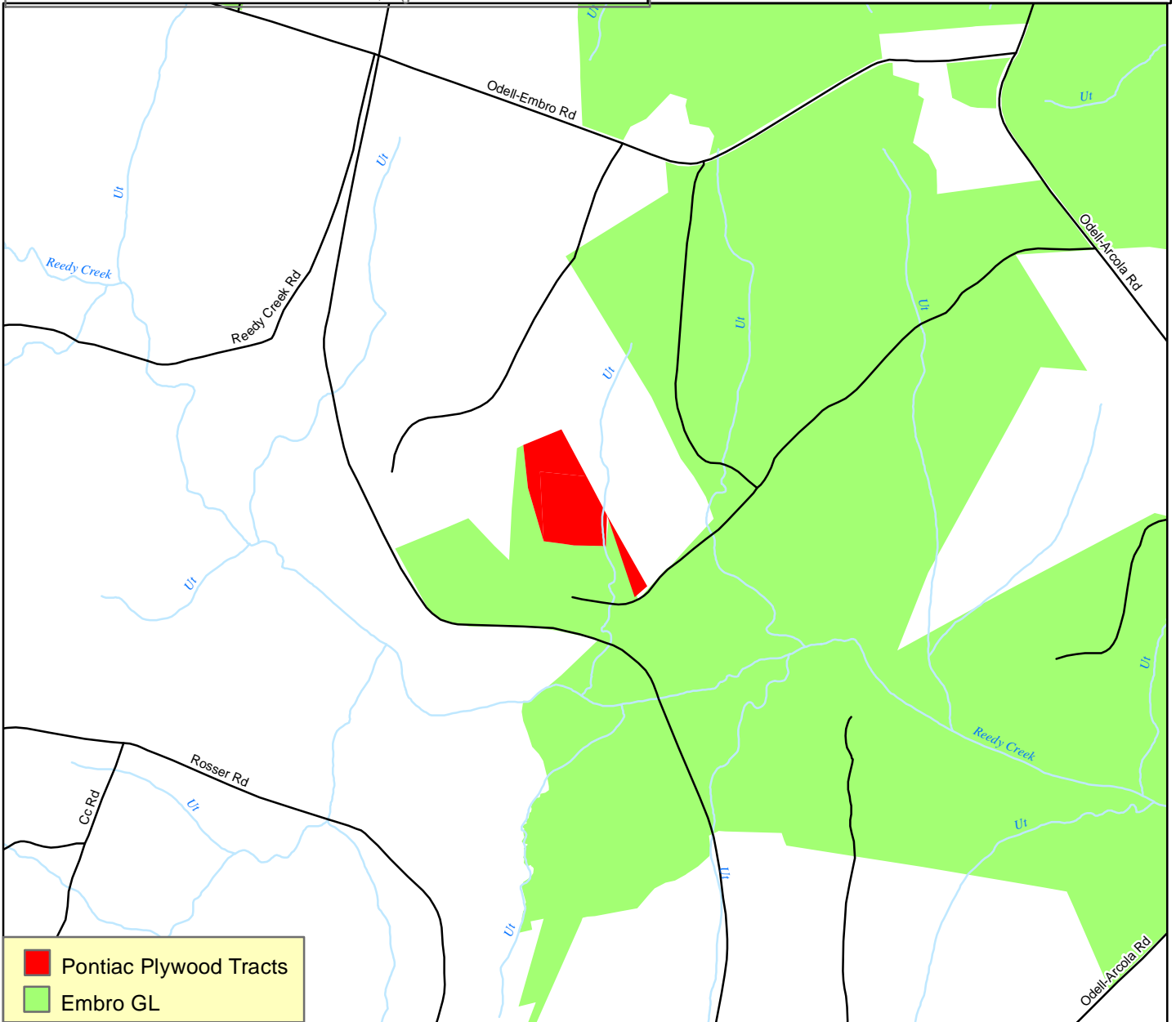
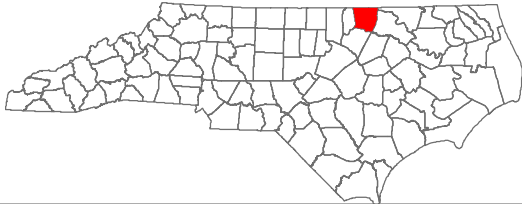

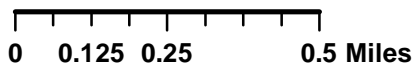

November 13, 2015

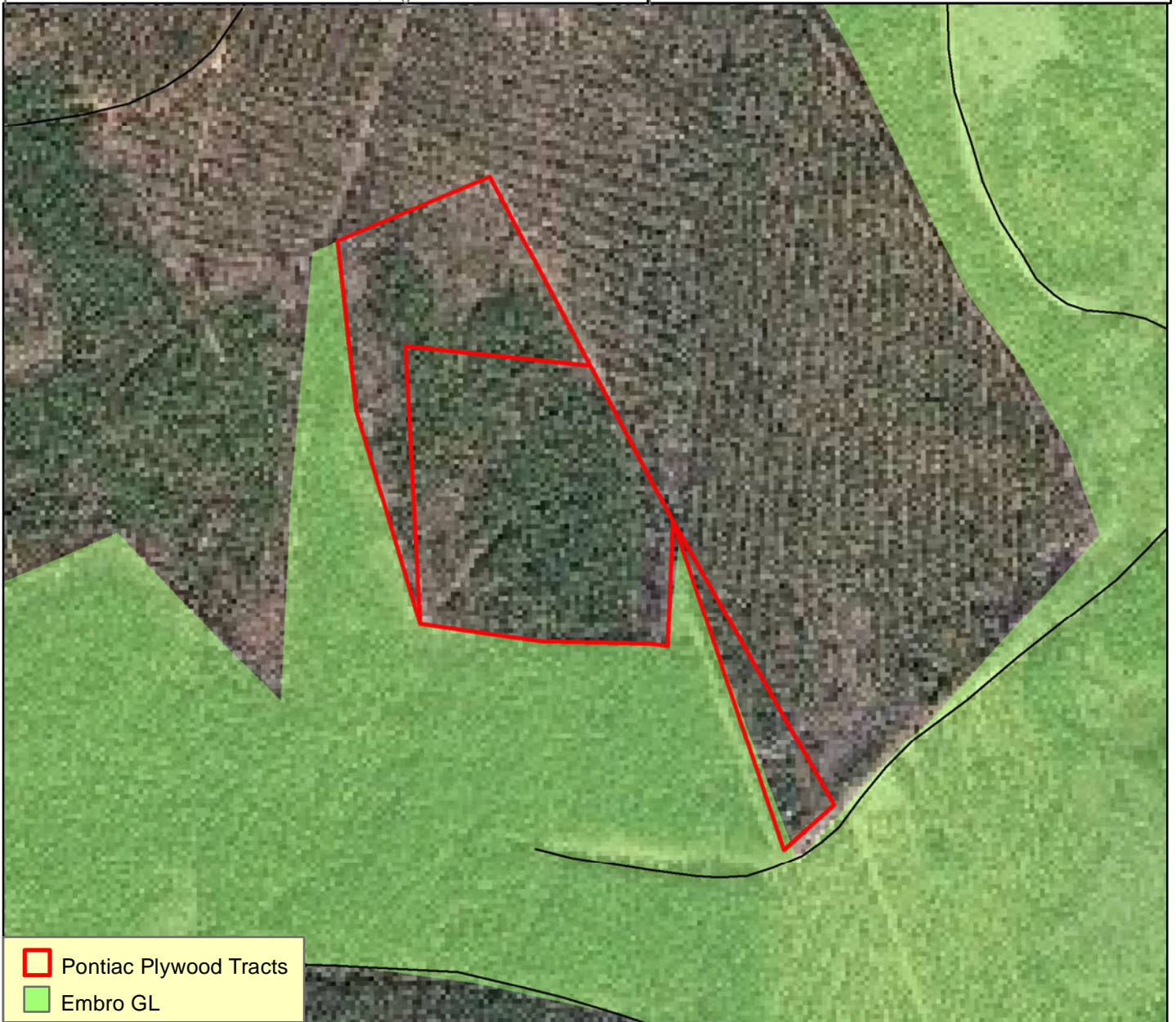
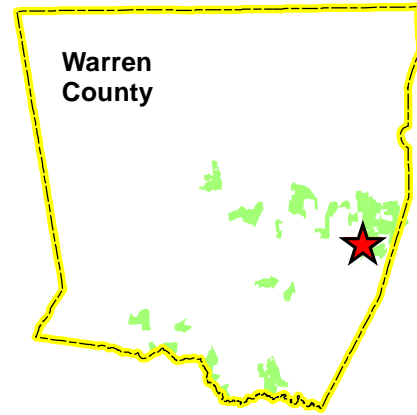
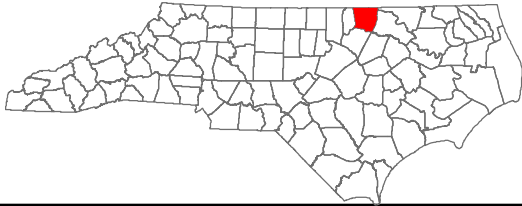

**Pontiac Plywood Tracts  
Embro GL  
Warren County  
19 Acres**



 Pontiac Plywood Tracts  
 Embro GL



November 13, 2015

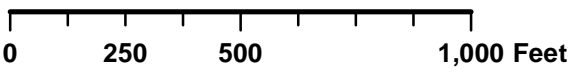



# EXHIBIT C-5

December 10, 2015

## North Carolina Wildlife Resources Commission Land Acquisition Investigation Form

### -PHASE I: INITIAL INVESTIGATION-

---

**WRC Staff Contact:** Gordon Warburton/David Stewart

**Date First Presented to WRC:** December 10, 2015.

Craig Tweed originally approached WRC in 2008 and expressed interest in selling the tract. However, the tract was priced very high at that time and went unsold for several years. Recently, two smaller sections of tract have been sold. WRC approached Mr. Tweed July 2014 and determined that the balance of the tract is still for sell.

**Tract Name:** Tweed Tract (PINNUM 971314442100000)

**Acreage:** 87

**County:** Buncombe

**Estimated Value:** \$530,000 Asking Price

**Property Owner or Representative:** Craig Tweed

**Phone:** 828-691-9098

**Address:** 41 Martin Candler Road Alexander NC 28701

**Status:**  High Interest       Moderate Interest       Low Interest       No Interest

**Grant Potential:**  CWTF

OTHER (explain): Pittman Robertson Land Acquisition Grant, Southern Appalachian Highlands Conservancy

**Resources Assessment and Biological Benefits (brief):** Acquisition of this property is significant as part of the total management project being carried out in the Sandy Mush area. Acquisition of the Tweed tract is particularly significant since it would connect existing smaller tracts of Sandy Mush Game Land that are currently isolated. In a broader sense, WRC ownership of the tract will help ensure ecosystem integrity at the landscape level by increasing connectivity of lands in conservation ownership such as Pisgah National Forest, Sandy Mush Game Land (WRC holdings), Southern Appalachian Highlands Conservancy lands and various private holdings that are in conservation ownership or have conservation easements that are located in the vicinity. WRC ownership will help reduce land fragmentation as well.

A small portion of the tract is forested with Appalachian oak, Appalachian cove, and Southern Appalachian Low Elevation Pine forests, while the majority of the tract is early successional open fields. Management objectives will include restoring or maintaining the priority wildlife habitats, such as early successional and shortleaf pine, that are located on the tract. The Wildlife Action Plan identifies early successional habitats as priority habitats. The openness of the Tweed Tract is ideal for quality early successional habitat restoration. Common wildlife species found on the tract include quail, grouse, wild

turkey, white-tailed deer, and gray squirrel. Priority species likely to occur on the tract are identified in the attached table.

The Tweed tract is immediately adjacent the Sandy Mush Game Land and has over 3000 feet of public road frontage providing excellent access. Public recreational opportunities will include hunting, hiking, bird watching, photography, and general nature study. Educational opportunities may exist as priority wildlife habitats are managed for or maintained.

**Additional Comments:** The Tweed Tract is identified in the Sandy Mush Game Land Management Plan as a Level 1 priority tract for acquisition. Level 1 gives this tract a high priority for acquisition.

The Tweed tract is located off of Martin Candler Road and adjoins a small, existing tract of game land. Acquisition of the Tweed tract would enlarge this existing tract and connect it to the larger tract of the Sandy Mush Game Land, thus alleviating the complexities of the boundaries at this location.

Mr. Tweed has shown a willingness to sell portions of this tract. Acquisition will eliminate additional fragmentation in this immediate area, thus protecting existing habitats and corridors that are currently occupied by a wide array of wildlife.

Preliminary estimates of five-year stewardship expenditures include marking/maintaining 2 miles of property boundary (\$400), installing 5 gates (\$5,000) and developing 1 small parking area (\$1000) for a total estimated cost of \$6,400.

No short-term revenue is projected from the tract

**Program Potential:**     Game Land (Sandy Mush)                       Wildlife Conservation Area  
                                  Fishing Access Area     None

**Potential Source(s) of Stewardship Funds (indicate federal: state match rates):** Pittman-Robertson Federal Assistance Grant (75% federal: 25% state)

**Relative Priority Evaluation Score (attach worksheet):** 29 of 30

**Recommendation:**  Pursue Acquisition             Defer             Do not Pursue Acquisition

**Map Attached:**  Yes             No

**Tweed Tract (Buncombe County) - Priority Species**

SCIENTIFIC NAME	COMMON NAME	FED LISTED	STATE LISTED
<b>AMPHIBIANS</b>			
scientific name	commom name	Federally Listed	NC state listed
Plethodon glutinosus	Slimy Salamander		
Plethodon ventralis	Southern Zigzag Salamander		SC
Desmognathus wrighti	Pygmy Salamander		SR
Hemidactylium scutatum	Four-toed Salamander		SC
Ambystoma talpoideum	Mole Salamander		SC
Necturus maculosus	Mudpuppy		SC
Cryptobranchus alleganiensis	Hellbender		SC
<b>BIRDS</b>			
Accipiter striatus	Sharp-shinned Hawk		SR
Falco sparverius	American Kestrel		
Falco peregrinus	Peregrine Falcon		E
Coccyzus erythrophthalmus	Black-billed Cuckoo		SR
Tyto alba	Barn Owl		SR
Sphyrapicus varius	Yellow-bellied Sapsucker		
Empidonax alnorum	Alder Flycatcher		SR
Empidonax minimus	Least Flycatcher		
Vireo gilvus	Warbling Vireo		SR
Corvus corax	Common Raven		
Sitta canadensis	Red-breasted Nuthatch		
Certhia americana	Brown Creeper		SC
Troglodytes troglodytes	Winter Wren		
Regulus satrapa	Golden-crowned Kinglet		
Vermivora pinus	Blue-winged Warbler		SR
Vermivora chrysoptera	Golden-winged Warbler		SC
Dendroica magnolia	Magnolia Warbler		SR
Dendroica cerulea	Cerulean Warbler		SC
Limnothlypis swainsonii	Swainson's Warbler		
Poocetes gramineus	Vesper Sparrow		SC
Ammodramus savannarum	Grasshopper Sparrow		
Icterus galbula	Baltimore Oriole		
<b>MAMMALS</b>			
Sorex dispar	Long-tailed Shrew		SC
Sorex hoyi	Pygmy Shrew		
Corynorhinus rafinesquii	Rafinesque's Big-eared Bat		T
Lasiurus cinereus	Hoary Bat		
Lasiurus seminolus	Seminole Bat		
Myotis septentrionalis	Northern Myotis		
Myotis leibii	Eastern Small-footed Myotis		SC
Sylvilagus obscurus	Appalachian Cottontail		SR-G
Zapus hudsonius	Meadow Jumping Mouse		
Mustela nivalis	Least Weasel		SR-G
Spilogale putorius	Eastern Spotted Skunk		
<b>REPTILES</b>			
Glyptemys muhlenbergii	Bog Turtle	LT, SAT	T
Apalone spinifera spinifera	Eastern Spiny Softshell		SC
Eumeces anthracinus	Coal Skink		SR
Lampropeltis triangulum elapsoides	Scarlet Kingsnake		
Lampropeltis triangulum triangulum	Eastern Milk Snake		
Virginia valeriae	Smooth Earth Snake		

**WORKSHEET**  
**Five Year Stewardship Costs and Revenue Projections**  
**(Five Years Post Acquisition)**

STEWARDSHIP						
Estimated Stewardship Expenditures						
Tract Name	Activity	Quantity	Unit	Unit Cost	Total Cost	
Tweed	Boundary Establishment	2.0	mi.	\$200	\$ 400.00	
	Install Gates	5	ea.	\$1,000	\$5,000.00	
	Develop Parking Area	1	ea.	\$1,000	\$1,000.00	
<b>Total</b>					<b>\$ 6,400.00</b>	
<i>Insert additional rows in table as needed</i>						

REVENUE						
Estimated Revenue Projections						
Tract Name	Source	Quantity	Unit	Unit Revenue	Total Revenue	
Tweed	NA	NA	NA	NA	\$ -	
<b>Total</b>					<b>\$ -</b>	
<i>Insert additional rows in table as needed</i>						



**WORKSHEET**  
**Relative Priority Evaluation for Conservation Lands**

Tract Name (Sandy Mush GL)     Tweed Tract (Buncombe County)    

Criterion	Score (1-5) 5=Excellent 1=Poor
1. Augments existing protected lands by addressing an inholding or adjacent tract, provides key access, buffers or connects existing WRC-managed lands.	<u>5</u>
2. Represents good hunting, fishing, wildlife viewing, and other resource-based recreational opportunities.	<u>5</u>
3. No conflicting surrounding land uses.	<u>4</u>
4. Serves as a wildlife corridor between areas already protected for conservation purposes and provides connectivity to priority Wildlife Action Plan habitats.	<u>5</u>
5. Augments land conservation efforts on a landscape scale by providing nuclei (“anchors”) for regional conservation efforts, corridors, key linkages between conservation areas, or keystone tracts.	<u>5</u>
6. Fills a need identified by the Wildlife Action Plan, such as critical, rare or unique habitats; natural heritage elements; or significant aquatic/terrestrial resources.	<u>5</u>
7. Is this an area in which we would like to establish a new game land, wildlife conservation area, or fishing access?	<u>N/A</u>
8. Is it large enough to be a new game land, and if not, are there possibilities for expansion (goal 3,000-5,000 acre minimum)?	<u>N/A</u>
9. Is area adequate for fishing access development with suitable parking, and if not, are there possibilities for expansion?	<u>NA</u>
<b>TOTAL SCORE</b>	<u><u>29</u></u>

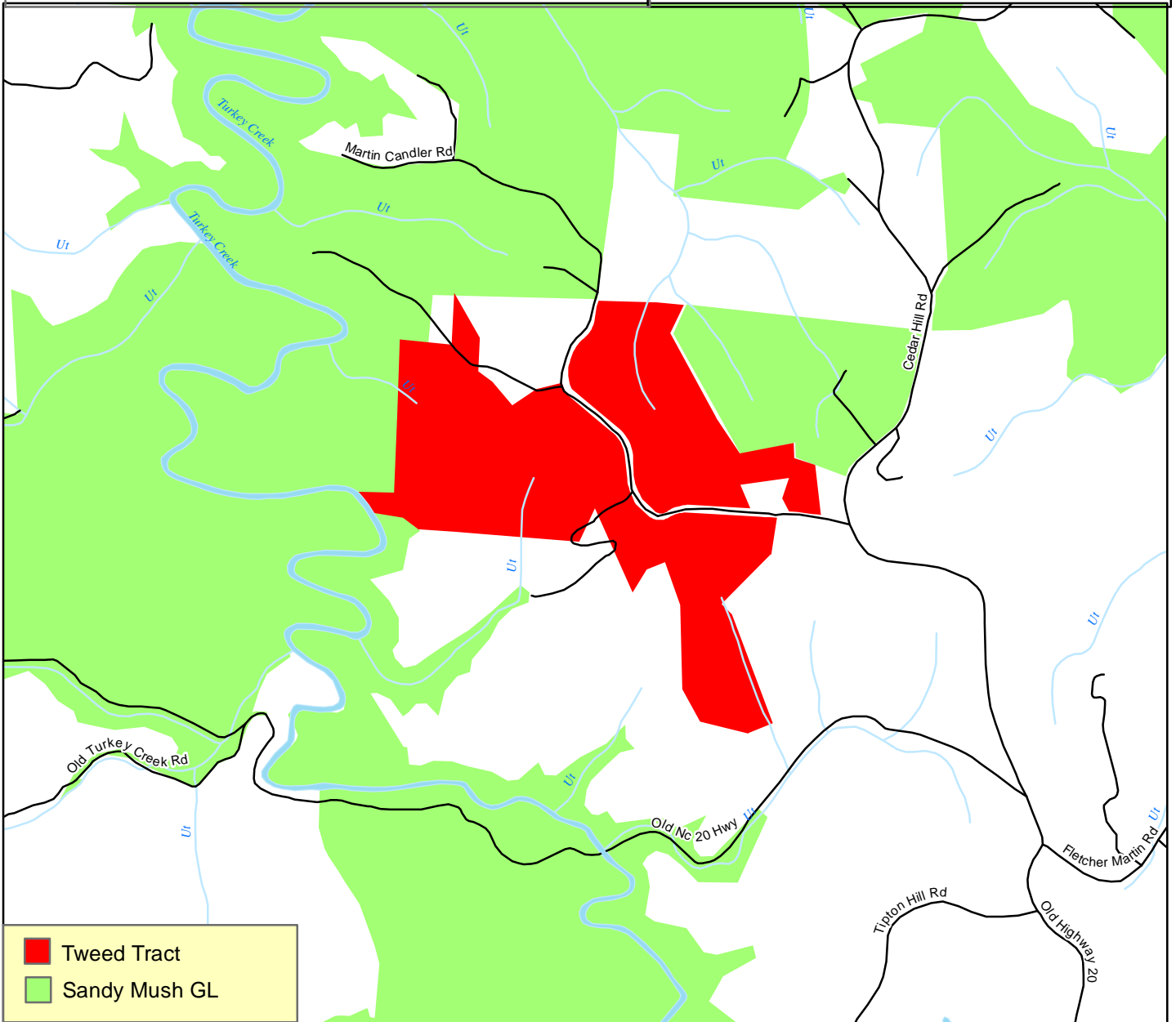
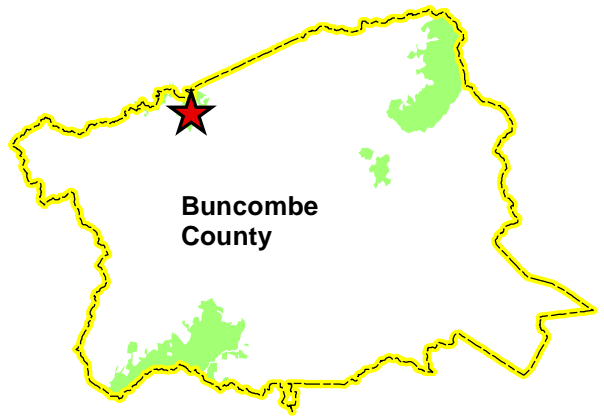
# Tweed Tract Sandy Mush Game Land Buncombe County 87 Acres



-  Tweed Tract
-  Sandy Mush GL



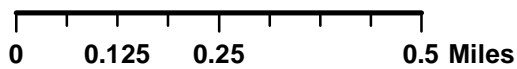

November 9, 2015

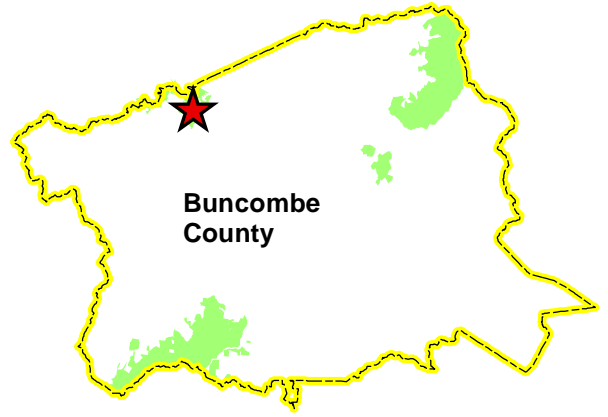

# Tweed Tract Sandy Mush Game Land Buncombe County 87 Acres



-  Tweed Tract
-  Sandy Mush GL



November 9, 2015

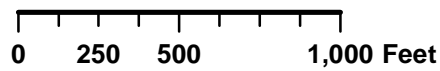

# EXHIBIT D

December 10, 2015

## North Carolina Wildlife Resources Commission Land Acquisition Investigation Form

### -PHASE II: FINAL ACQUISITION DETAILS-

WRC Action/Approval to Pursue (Date): May 21, 2015

Tract: Caldwell Tract; Haywood County, 60 Acres

Acquisition Plan (specify total project cost, each source, and amount of OBLIGATED funds):

Pitman Robertson Land Acquisition Grant	\$ 270,000
Southern Appalachian Highlands Conservancy	\$ 90,000
Total Cost:	<u>\$ 360,000 (\$6,000/Acre)</u>

Based on Appraisal:  Yes  No  NA

If Yes, Name of Appraiser:

Requested by:	Appraiser	Effective Date	Appraised Value
WRC	CDN Appraisal	7/14/15	\$ 360,000 (\$ 6,000/Acre)

Date of Appraisal: See above.

Appraisal Handled by State Property Office:  Yes  No  NA

Acquisition Plan Includes Bargain Sale:  Yes  No

If Yes, Explain Details:

Source(s) of Stewardship Funds (indicate federal:state match rates):

Pittman-Robertson Federal Assistance Grant (75% federal: 25% state)

Five Year Stewardship Costs & Revenue Projection Evaluation (attach worksheet)

Five Year Estimate of Total Stewardship Expenditures: \$:

Five Year Estimate of Total Projected Revenue: \$:

Additional Comments: NA



**WORKSHEET**  
**Five Year Stewardship Costs and Revenue Projections**  
**(Five Years Post Acquisition)**

STEWARDSHIP							
		Estimated Stewardship Expenditures					
Tract Name	Activity	Quantity	Unit	Unit Cost	Total Cost		
Caldwell	Establish Boundary	1.0	mi.	\$810	\$ 810.00		
		<b>Total</b>				<b>\$ 810.00</b>	
<i>Insert additional rows in table as needed</i>							

REVENUE							
		Estimated Revenue Projections					
Tract Name	Source	Quantity	Unit	Unit Revenue	Total Revenue		
Caldwell	NA	NA	NA	NA	\$	-	
		<b>Total</b>				<b>\$</b>	<b>-</b>
<i>Insert additional rows in table as needed</i>							

**North Carolina Wildlife Resources Commission  
Land Acquisition Investigation Form**

**-PHASE I: INITIAL INVESTIGATION-**

---

**WRC Staff Contact:** Gordon Warburton/David Stewart

**Date First Presented to WRC:** May 21, 2015 (staff first investigated tract in 2001)

**Tract Name:** Caldwell Tract (PIN: 8632-97-4495)

**Acreage:** 60

**County:** Haywood

**Estimate Value:** \$350,000 Asking Price

**Property Owner or Representative:** Wade Caldwell (Owner)

**Phone:** (828) 242-1041(Daughter, Joy Penland)

**Address:** 15 Old 19-23 Hwy Candler, NC 28715

**Status:**  High Interest       Moderate Interest       Low Interest       No Interest

**Grant Potential:**  CWMTF

OTHER (explain): Pittman Robertson Land Acquisition Grant, Southern Appalachian Highlands Conservancy (SAHC)

**Resources Assessment and Biological Benefits (brief):** Acquisition of this property is significant as part of the total management project being carried out in the Cold Mountain area. In a broader sense, WRC ownership of the tract will help ensure ecosystem integrity at the landscape level by increasing connectivity of lands in conservation ownership such as Pisgah National Forest, Cold Mountain Game Land (WRC holdings), Southern Appalachian Highlands Conservancy (SAHC) lands and various private holdings that have conservation easements that are located in the vicinity. The property directly borders the Cold Mountain Game Lands. WRC ownership will help reduce land fragmentation and will help ensure that this area is protected and managed properly. The tract lies adjacent to significant Natural Heritage Areas and consists primarily of upland/cove hardwoods with 15-20 acres of open pastureland. The timber on the property appears to be of very high quality with large yellow poplar, oak, and black cherry being the most valuable timber species. Common wildlife species found on the tract include wild turkey, white-tailed deer and black bear. Priority species likely to occur on the tract are identified in the attached table. Public recreational opportunities will include hunting, hiking,

bird watching, photography and general nature study. Educational opportunities may exist as priority wildlife habitats are managed for or maintained.

**Additional Comments:** The total area of the Caldwell Tract is 70.62 acres. Mr. Caldwell is keeping his small cabin and approximately 10 acres.

Preliminary estimates of five-year stewardship expenditures include marking and maintaining approximately 1 mile of property boundary. Total estimate of five-year expenditures is \$810.

No short-term revenue is projected from the tract.

**Program Potential:**  Game Land (Cold Mountain)       Wildlife Conservation Area  
 Fishing Access Area       None

**Potential Source(s) of Stewardship Funds (indicate federal:state match rates):** Pittman-Robertson Federal Assistance Grant (75% federal: 25% state)

**Relative Priority Evaluation Score (attach worksheet):**

**Recommendation:**  Pursue Acquisition     Defer       Do not Pursue Acquisition

**Map Attached:**  Yes       No

**Caldwell Tract (Haywood County) - Wildlife Action Plan Priority Species**

<b>SCIENTIFIC NAME</b>	<b>COMMON NAME</b>	<b>FED LISTED</b>	<b>STATE LISTED</b>
<b>AMPHIBIANS</b>			
<i>Plethodon glutinosus</i>	Slimy Salamander		
<i>Plethodon ventralis</i>	Southern Zigzag Salamander		SC
<i>Desmognathus wrighti</i>	Pygmy Salamander		SR
<i>Hemidactylium scutatum</i>	Four-toed Salamander		SC
<b>BIRDS</b>			
<i>Accipiter striatus</i>	Sharp-shinned Hawk		SR
<i>Falco sparverius</i>	American Kestrel		
<i>Coccyzus erythrophthalmus</i>	Black-billed Cuckoo		SR
<i>Tyto alba</i>	Barn Owl		SR
<i>Empidonax alnorum</i>	Alder Flycatcher		SR
<i>Certhia americana</i>	Brown Creeper		SC
<i>Vermivora chrysoptera</i>	Golden-winged Warbler		SC
<i>Dendroica cerulea</i>	Cerulean Warbler		SC
<i>Limnothlypis swainsonii</i>	Swainson's Warbler		
<i>Ammodramus savannarum</i>	Grasshopper Sparrow		
<b>MAMMALS</b>			
<i>Sorex hoyi</i>	Pygmy Shrew		
<i>Lasiurus cinereus</i>	Hoary Bat		
<i>Sylvilagus obscurus</i>	Appalachian Cottontail		SR
<i>Zapus hudsonius</i>	Meadow Jumping Mouse		
<i>Mustela nivalis</i>	Least Weasel		SR
<b>REPTILES</b>			
<i>Eumeces anthracinus</i>	Coal Skink		SR
<i>Virginia valeriae</i>	Smooth Earth Snake		

## WORKSHEET

### Relative Priority Evaluation for Conservation Lands

Tract Name (Cold Mountain GL)     Caldwell Tract (Haywood County)    

Criterion	Score (1-5) 5=Excellent 1=Poor
1. Augments existing protected lands by addressing an inholding or adjacent tract, provides key access, buffers or connects existing WRC-managed lands.	<u>5</u>
2. Represents good hunting, fishing, wildlife viewing, and other resource-based recreational opportunities.	<u>5</u>
3. No conflicting surrounding land uses.	<u>5</u>
4. Serves as a wildlife corridor between areas already protected for conservation purposes and provides connectivity to priority Wildlife Action Plan habitats.	<u>5</u>
5. Augments land conservation efforts on a landscape scale by providing nuclei (“anchors”) for regional conservation efforts, corridors, key linkages between conservation areas, or keystone tracts.	<u>5</u>
6. Fills a need identified by the Wildlife Action Plan, such as critical, rare or unique habitats; natural heritage elements; or significant aquatic/terrestrial resources.	<u>5</u>
7. Is this an area in which we would like to establish a new game land, wildlife conservation area, or fishing access?	<u>NA</u>
8. Is it large enough to be a new game land, and if not, are there possibilities for expansion (goal 3,000-5,000 acre minimum)?	<u>NA</u>
9. Is area adequate for fishing access development with suitable parking, and if not, are there possibilities for expansion?	<u>NA</u>
<b>TOTAL SCORE</b>	<u><u>30</u></u>

# Caldwell Tract Cold Mountain GL Haywood County 60 Acres

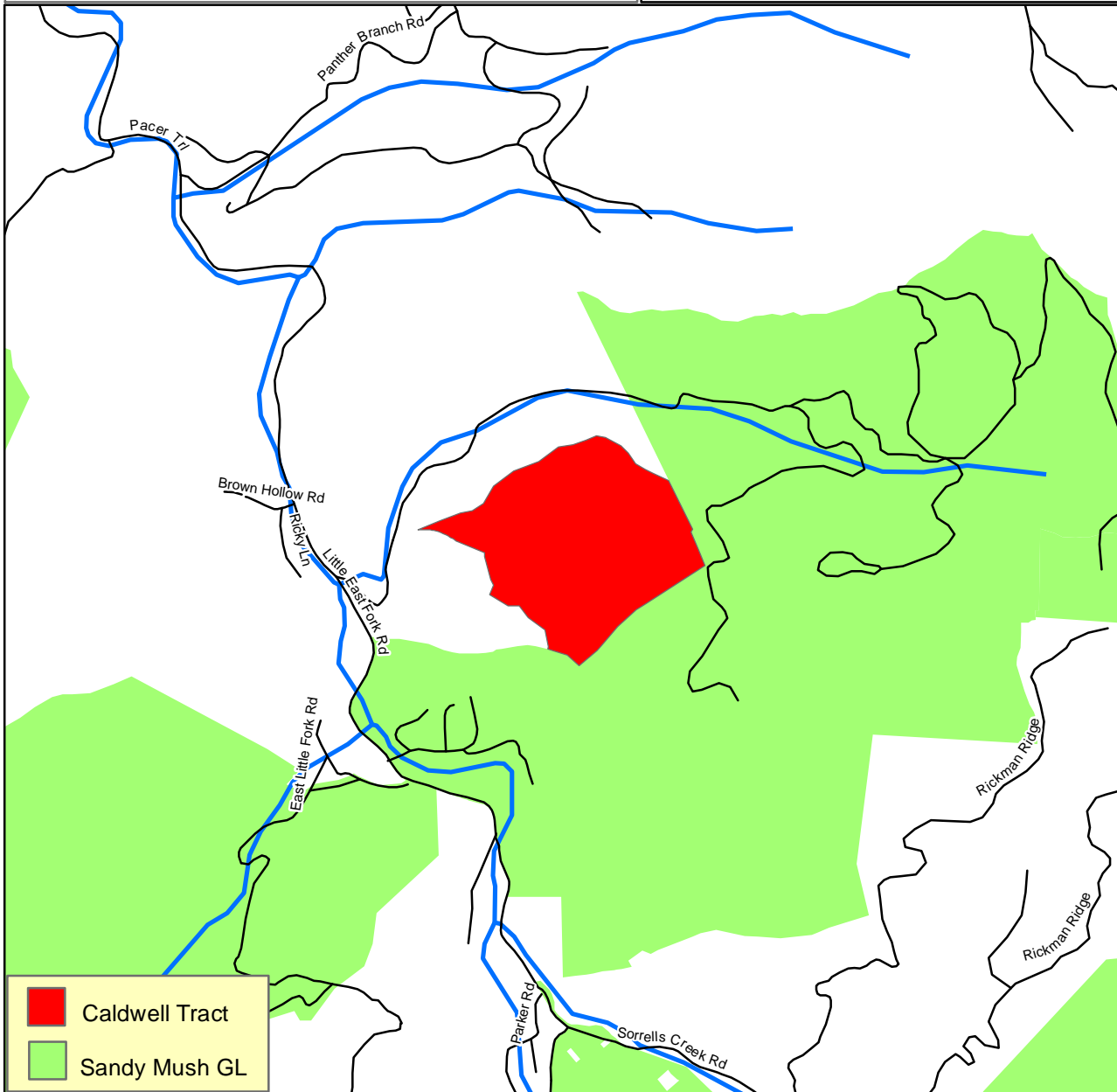

February 8, 2015

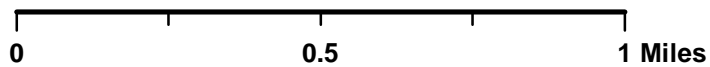

**Caldwell Tract  
Cold Mountain GL  
Haywood County  
60 Acres**

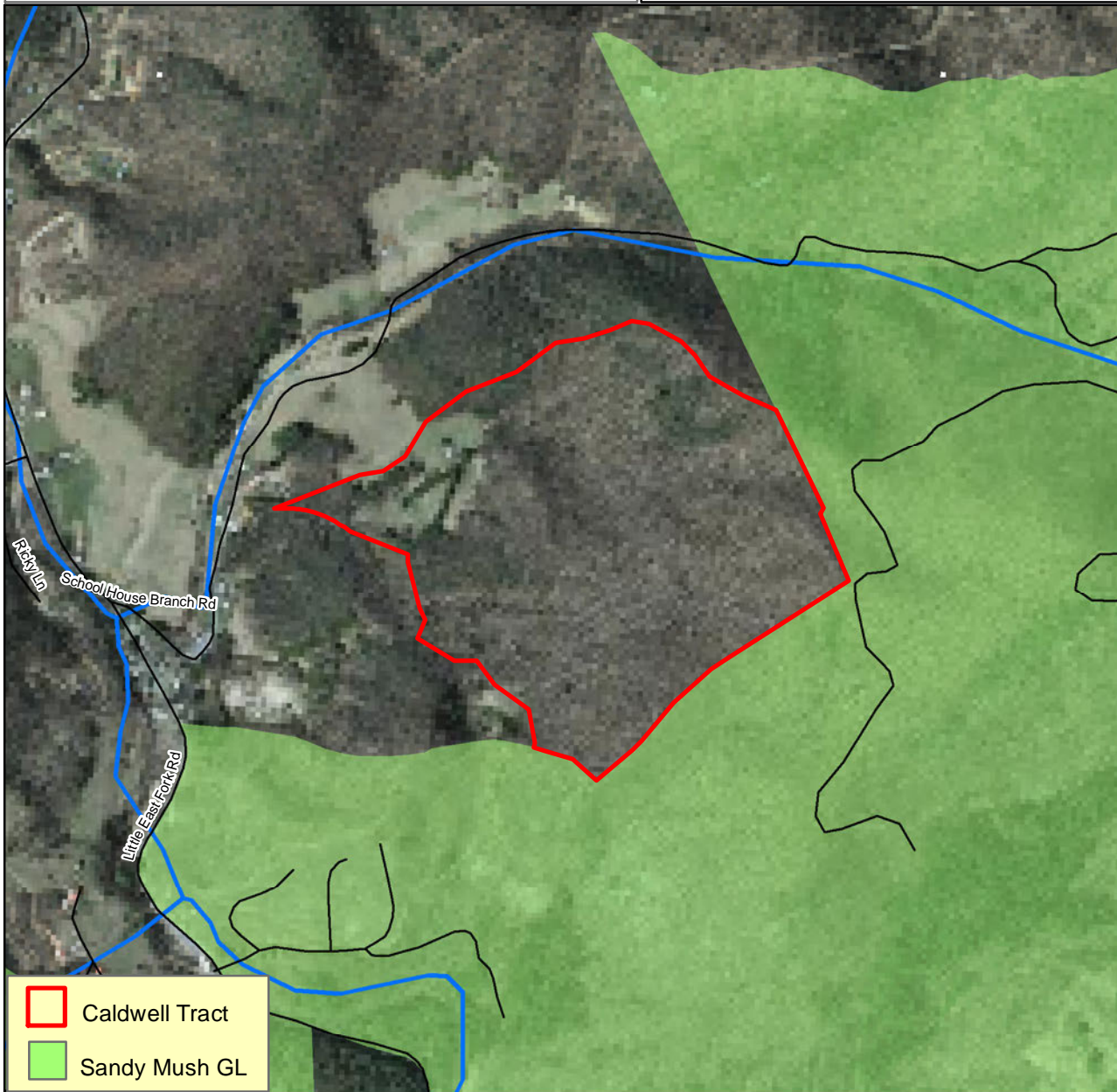

February 8, 2015

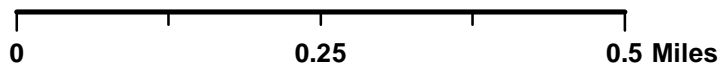

# EXHIBIT E

December 10, 2015



## ⊠ North Carolina Wildlife Resources Commission ⊠

---

November 23, 2015

### MEMORANDUM

TO: Erik Christofferson, Deputy Director  
Operations

FROM: Isaac Harrold, Lands Program Manager  
Land and Water Access Section

SUBJECT: DOT Permanent & Temporary Easement Requests  
Sandhills Game Land – Scotland County  
Bridge No. 8 over Lumber River on Turnpike Road (SR1412/SR1203)  
TIP Project: B-4967

NC Department of Transportation (DOT) has requested temporary construction and permanent drainage easements on a portion of Sandhills Game Land to facilitate a bridge improvement project over the Lumber River on Turnpike Road in Scotland County.

DOT has identified the need for permanent drainage easement of 0.115 acres and temporary construction easement of 0.198 acres.

Staff identified no significant negative impacts and recommends approval.

Land and Water Access Section  
Mailing Address: 1720 Mail Service Center, Raleigh, N.C. 27699-1720  
Physical Address: 1751 Varsity Drive, Raleigh, N.C. 27606  
Phone: 919-707-0150 Fax: 919-707-0162



**SANDHILLS GAME LAND (continued)**

**NCDOT TEMPORARY (0.198 AC.) AND PERMANENT (0.115 AC.) EASEMENT REQUEST  
BRIDGE #8 OVER LUMBER RIVER ON TURNPIKE ROAD**

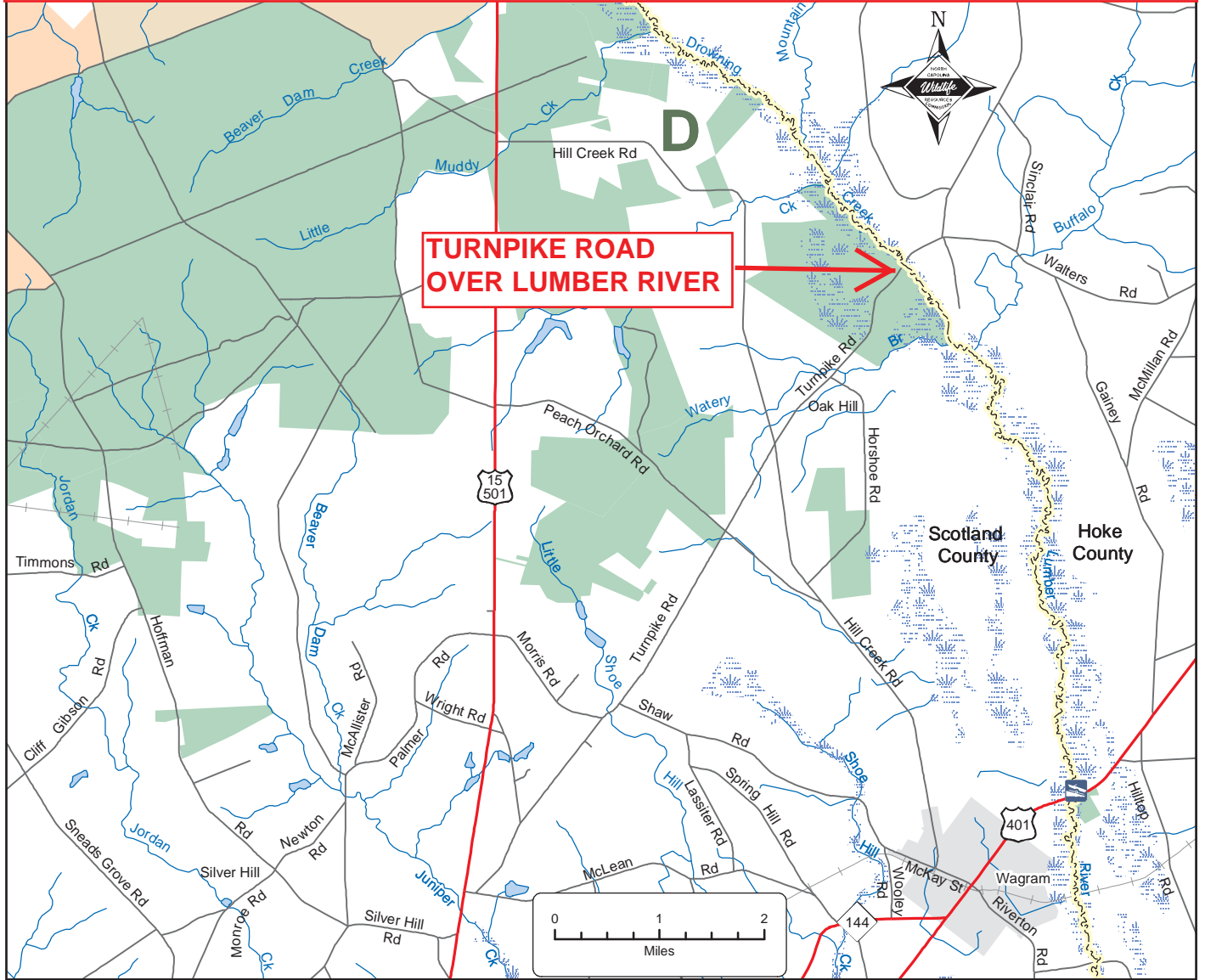

# EXHIBIT F

December 10, 2015



## ⊠ North Carolina Wildlife Resources Commission ⊠

---

November 23, 2015

### MEMORANDUM

TO: Erik Christofferson, Deputy Director  
Operations

FROM: Isaac Harrold, Lands Program Manager  
Land and Water Access

SUBJECT: Easement Amendment  
Public Service Company of North Carolina  
Green River Game Land, Polk County

Public Service Company of North Carolina (PSNC) currently has a gas line easement on a portion of Green River Game Land in Polk County and plans to replace the existing pipeline in the near future (see attached map for general project location). The work will occur within the footprint of the existing pipeline. However, the current easement document does not specify the easement location or width of the easement area. PSNC Energy would like to rectify this situation by amending the current easement document to specify the easement location and width (see attached "State Amended and Restated Easement"). The proposed amendment identifies a total of 0.21 acres of permanent easement within five locations along our game land boundary.

PSNC Energy has also requested a temporary easement immediately adjacent to the permanent R/W location to facilitate pipeline construction activities and storage of materials, equipment, and vehicles (see attached "NC State Temporary Easement"). Detailed drawings are included in the above legal documents. The temporary easement area requested totals 1.84 acres.

Land and Water Access Section  
Mailing Address: 1720 Mail Service Center, Raleigh, N.C. 27699-1720  
Physical Address: 1751 Varsity Drive, Raleigh, N.C. 27606  
Phone: 919-707-0150 Fax: 919-707-0162

Planned work will generally occur along the boundary between the game land and several private properties. PSCN Energy will be responsible for re-establishing any marked game land boundary that is destroyed as a result of the pipeline replacement. Otherwise, WRC staff has reviewed this request and has determined that it will have no adverse effect on Green River Game Land.

Staff recommends seeking WRC approval to amend the existing permanent easement and to also grant approval of the temporary construction easement request.

# PSNC Easement Request



## Legend

PSNC Project Area

Green River Game Land



0 0.125 0.25 0.5 Miles

**AMENDED AND RESTATED EASEMENT**

Prepared By:  
Matthew D. Rhoad, Esq.  
Smith Anderson Law Firm  
P.O. Box 2611  
Raleigh, NC 27602  
(No Opinion on Title)

Return To:  
SCANA Corporation  
Attn: Craig Bodie  
800-A Gaston Rd.  
Gastonia, NC 28056

Line No.	T-001A Replacement
Parcel No.	P30-3
Project No.	0059354
R/W No.	PO-058
Check No.	
Date of Check	

STATE OF NORTH CAROLINA  
COUNTY OF POLK

**THIS AMENDED AND RESTATED EASEMENT** is made and entered into as of this \_\_\_\_ day of \_\_\_\_\_, 2015, by and between **State of North Carolina** (collectively, "**Grantor**") and **PUBLIC SERVICE COMPANY OF NORTH CAROLINA, INCORPORATED**, a South Carolina corporation d/b/a **PSNC ENERGY** ("**PSNC**").

WITNESSETH:

**WHEREAS**, Grantor is the owner of certain property located in Cooper Gap and White Oak Township, Polk County, North Carolina, being more particularly described in the instrument recorded in Book 226, Page 1813, Polk County Registry ("**Grantor's Property**");

**WHEREAS**, PSNC is the owner of a pipeline right of way that encumbers Grantor's Property, said right of way being more particularly described in that certain instrument recorded in Book 192, Page 1, Polk County Registry (the "**Easement**");

**WHEREAS**, the Easement does not specify the location or width of the pipeline easement area on Grantor's Property;

**WHEREAS**, the parties hereto desire to amend and restate the Easement to specify the location and width of the pipeline easement area on Grantor's Property as set forth herein.

**NOW, THEREFORE**, for and in consideration of the mutual promises contained herein and other good and valuable consideration, the receipt and legal sufficiency of which are hereby acknowledged, the parties hereby amend and restate the Easement such that the location and width of the pipeline easement area on Grantor's Property shall be as shown on **Exhibit A** attached hereto and incorporated herein (the "**Permanent Right of Way**").

**TO HAVE AND TO HOLD** the Amended Easement Area unto PSNC, its successors and assigns forever, upon the terms and conditions set forth herein and in the Easement. This Amended and Restated Easement shall run with Grantor's Property and does not supersede, modify, impair, or otherwise affect the Easement or PSNC's easements, rights, and privileges, thereunder, except as specifically set forth herein. Grantor hereby binds itself, its successors and assigns and any future owner(s) of Grantor's Property and/or the Amended Easement Area, to warrant and forever defend the easements, rights, and privileges granted unto PSNC, its successors and assigns herein and in the Easement, against every person whomsoever lawfully claiming or to claim the same or any part thereof.

**[Signature Page(s) Follow]**

**IN WITNESS WHEREOF**, Grantor and PSNC have executed this **AMENDED AND RESTATED EASEMENT** as of the day and year first above written.

Subscribing Witnesses: (Optional)

**GRANTOR:**

\_\_\_\_\_ Sign

\_\_\_\_\_ Sign

\_\_\_\_\_ Print

\_\_\_\_\_ Print

\_\_\_\_\_ Sign

\_\_\_\_\_ Sign

\_\_\_\_\_ Print

\_\_\_\_\_ Print

\_\_\_\_\_ Sign

\_\_\_\_\_ Sign

\_\_\_\_\_ Print

\_\_\_\_\_ Print

\_\_\_\_\_ Sign

\_\_\_\_\_ Sign

\_\_\_\_\_ Print

\_\_\_\_\_ Print

***[Notary Page(s) Follow]***

USE STANDARD ACKNOWLEDGMENT UNLESS THERE ARE SUBSCRIBING WITNESSES

STANDARD ACKNOWLEDGMENT

STATE OF NORTH CAROLINA

COUNTY OF \_\_\_\_\_

I, \_\_\_\_\_, a Notary Public of \_\_\_\_\_ County, North Carolina, do hereby certify that

\_\_\_\_\_, GRANTOR, personally appeared before me this day and acknowledged the due execution of the foregoing AMENDED AND RESTATED EASEMENT.

Witness my hand and seal this \_\_\_\_\_ day of \_\_\_\_\_, 2015.

\_\_\_\_\_  
Notary Public Sign  
\_\_\_\_\_  
Print

My Commission Expires: \_\_\_\_\_

SUBSCRIBING WITNESS ACKNOWLEDGMENT

STATE OF NORTH CAROLINA

COUNTY OF \_\_\_\_\_

I, \_\_\_\_\_, a Notary Public of \_\_\_\_\_ County, North Carolina, do hereby certify that \_\_\_\_\_

(subscribing witness) personally appeared before me this day and being duly sworn, stated that in his (her) presence \_\_\_\_\_,

GRANTOR, acknowledged the due execution of the foregoing AMENDED AND RESTATED EASEMENT.

Witness my hand and seal this \_\_\_\_\_ day of \_\_\_\_\_, 2015.

\_\_\_\_\_  
Notary Public Sign  
\_\_\_\_\_  
Print

My Commission Expires: \_\_\_\_\_

**IN WITNESS WHEREOF**, Grantor and PSNC have executed this **AMENDED AND RESTATED EASEMENT** as of the day and year first above written.

**PSNC:**

**PUBLIC SERVICE COMPANY  
OF NORTH CAROLINA, INCORPORATED**  
a South Carolina corporation  
d/b/a **PSNC ENERGY**

By: \_\_\_\_\_  
**George B. Ratchford, Vice President – Gas Operations**

STATE OF NORTH CAROLINA  
COUNTY OF GASTON

I, Martha W. Glover, a Notary Public of Gaston County, State of North Carolina, certify that George B. Ratchford personally appeared before me this day and acknowledged that he is Vice President – Gas Operations of **PUBLIC SERVICE COMPANY OF NORTH CAROLINA, INCORPORATED**, a South Carolina corporation d/b/a **PSNC ENERGY**, and that he, as Vice President – Gas Operations, being authorized to do so, voluntarily executed the foregoing on behalf of the corporation for the purposes stated therein.

Witness my hand and notarial stamp or seal, this \_\_\_\_ day of \_\_\_\_\_, 2015.

\_\_\_\_\_  
Martha W. Glover, Notary Public

My commission expires: March 9, 2019



# EXHIBIT A

## NOTES

1. ALL DISTANCES ARE HORIZONTAL GROUND DISTANCES.
2. AREAS DETERMINED BY COORDINATE METHOD.
3. AREAS SHOWN ARE SUBJECT TO EASEMENT OF RECORD.
4. RECORD REFERENCES: DEED BOOK 226, PAGE 1813.
5. PARCEL I.D. No. P30-3.
6. PROPERTY LINES SHOWN ARE BASED ON EXISTING DEEDS, PLATS AND VISIBLE MONUMENTATION DISCOVERED ALONG PROJECT AREA.
7. THIS SURVEY IS REFERENCED TO THE NORTH CAROLINA STATE PLANE COORDINATE SYSTEM NAD83 (2011).
8. ALL CORNERS ARE AS NOTED.
9. THIS PLAT IS FOR EASEMENT ACQUISITION PURPOSES ONLY AND IS NOT TO BE CONSIDERED A BOUNDARY SURVEY OF THE PARENT TRACT.
10. ALL TEMPORARY LAND RIGHTS WILL EXPIRE ON DECEMBER 31, 2016.

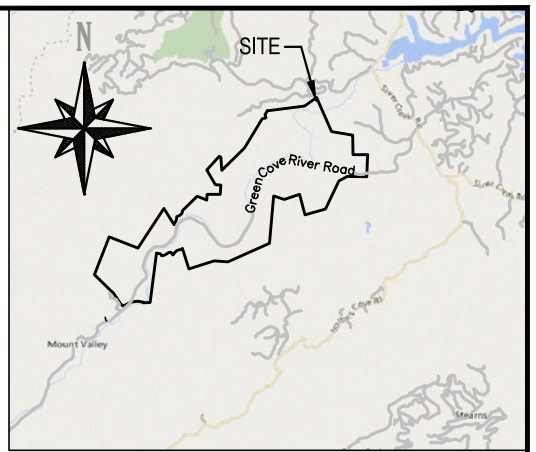
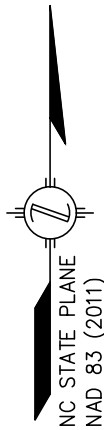

VICINITY MAP (NTS)

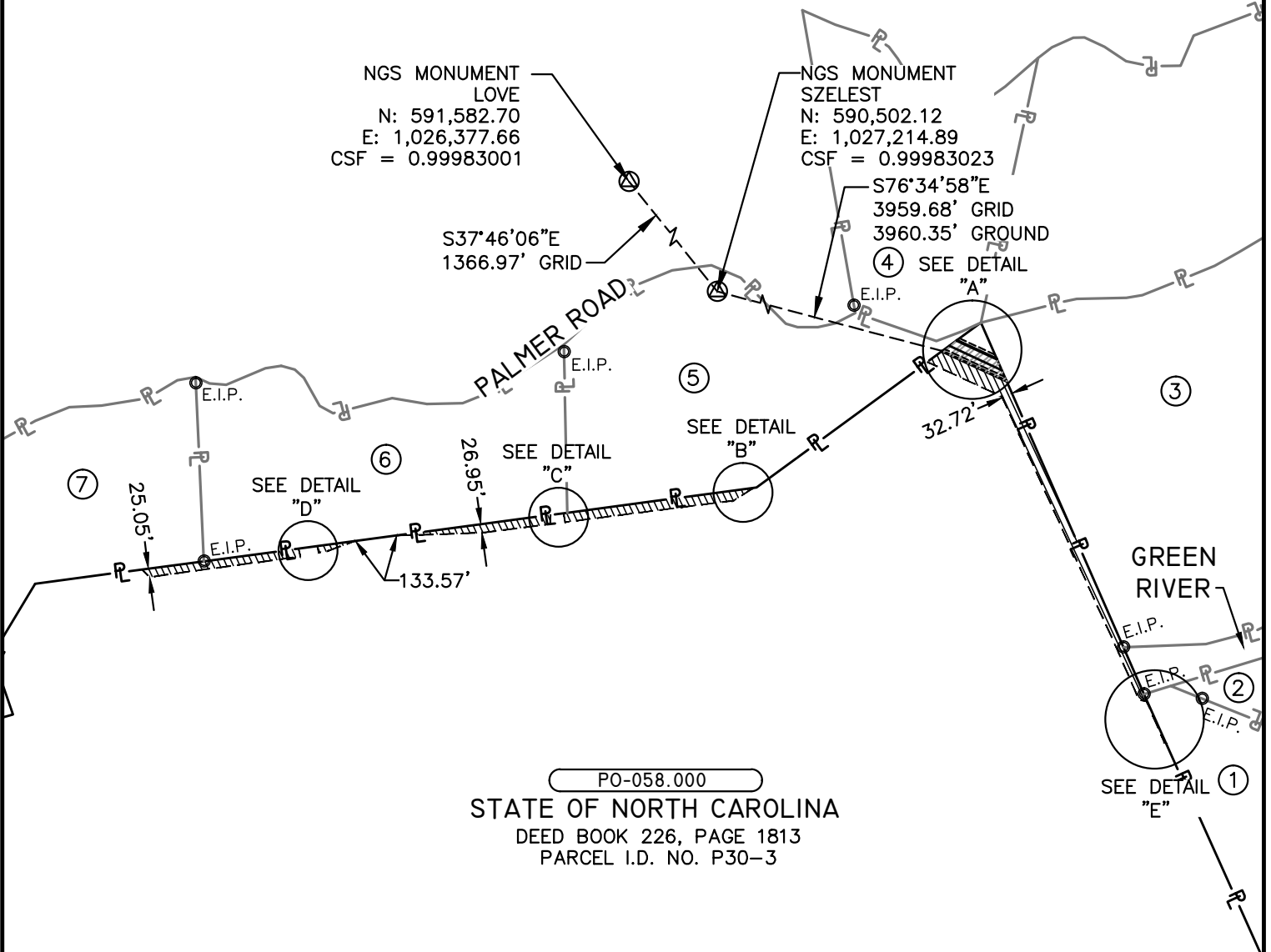

## LEGEND

- NGS MONUMENT
- EIP EXISTING IRON PIPE OR PIN
- IPS IRON PIN SET
- CP COMPUTED POINT
- LINE NOT TO SCALE
- R.O.W. RIGHT OF WAY
- PERMANENT RIGHT OF WAY
- TEMPORARY WORKSPACE
- ADDITIONAL TEMPORARY WORKSPACE
- EXISTING EASEMENT



I, John M. Story, certify that this plat was drawn under my supervision from an actual survey performed under my supervision (deed description recorded in Deed Book 226, Page 1813; that the ratio of precision as calculated is 1:10,000±; that the Global Positioning System (GPS) observations were performed to the Geospatial Positioning Accuracy Standards, Part 2: Standards for Geodetic Networks at the Class "A" accuracy classification (95% confidence) using RTK Network/ OPUS and traditional traverse.

That this plat meets the requirements of G.S. 47-30 section (f)(11)(d).

This 30 day of July, 2015.

*John M. Story*  
JOHN M. STORY, PLS L-3840

DONALDSON, GARRETT & ASSOCIATES, INC.  
9471-L SOUTHERN PINE BOULEVARD  
CHARLOTTE, N.C. 28273  
PH: (704) 374-1955 john.story@dg-anc.com  
NC CORPORATE LICENSE No. C-1518

SEE SHEET 2 OF 2 FOR  
LINE TABLES, DETAILS  
AND OWNERSHIP TABLE  
STATE OF NORTH CAROLINA

	sq. ft.	acres
AREA OF PERMANENT EASEMENT:	8,976±	0.21±
AREA OF TEMPORARY WORKSPACE:	80,241±	1.84±

	feet	rods
LENGTH OF PIPELINE:	180.53	10.94

EASEMENT SURVEY FPR PSNC ENERGY - T-001 REPLACEMENT COOPER GAP & WHITE OAK TOWNSHIP POLK COUNTY, NORTH CAROLINA				
SURFACE SITE IN PROPERTY OF STATE OF NORTH CAROLINA GREEN RIVER COVE ROAD, SALUDA, N.C. PO-058.000 DEED BOOK 226, PAGE 1813 53020-35-058				
Drawn By: S.B.B.	Chk'd By: R.J.W.	App'd By: J.M.S.	Proj. No. 53020000	Scale: 1"=600'
Drawn Date: 07/15/15			Sheet: 1 OF 2	PSNC Proj. No. 0059354
600 300 0 600 GRAPHIC SCALE IN FEET				
REVISIONS				
No.	Date	Rev By	Description	Checked

# EXHIBIT A

DETAIL "A"  
N.T.S.

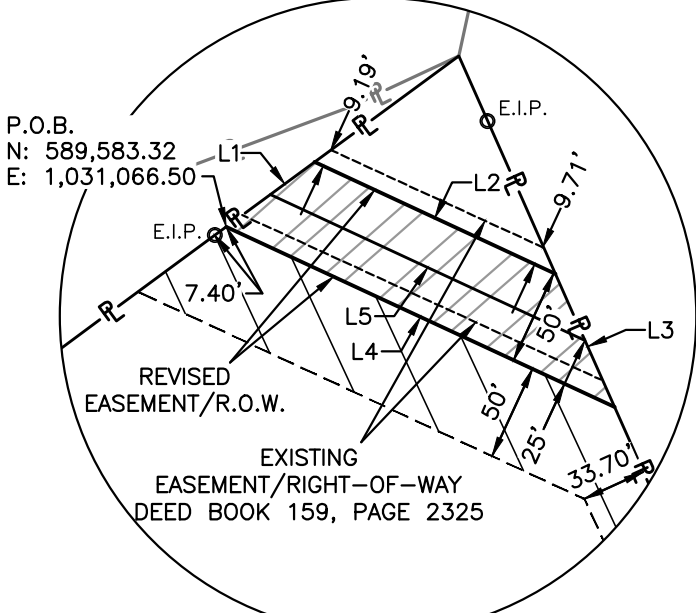

DETAIL "B"  
N.T.S.

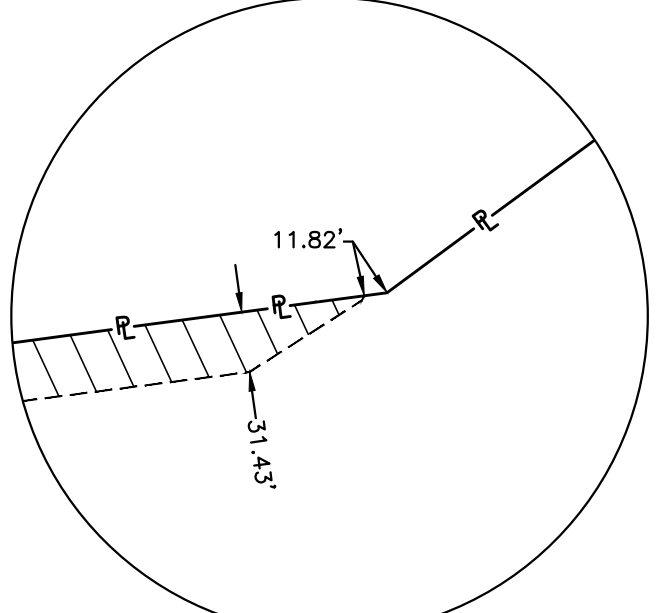

DETAIL "C"  
N.T.S.

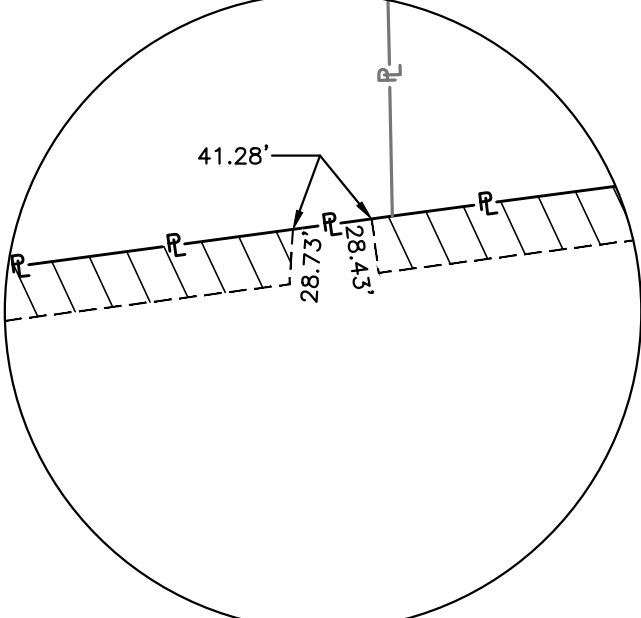

DETAIL "D"  
N.T.S.

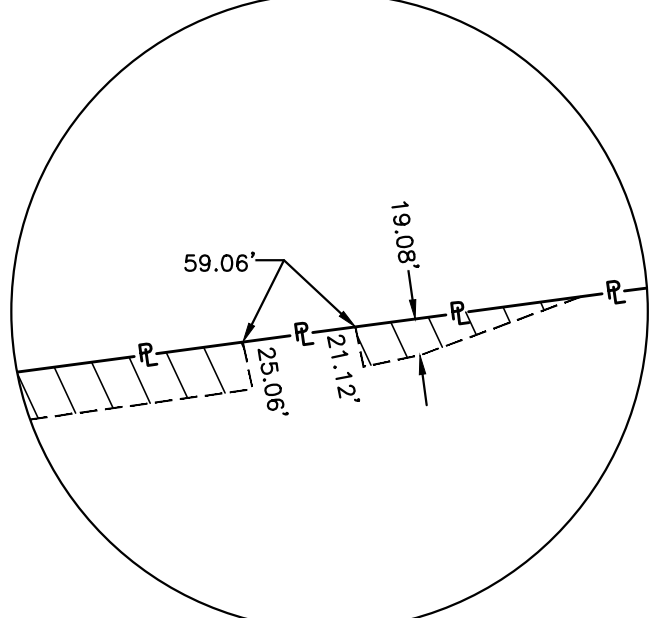

DETAIL "E"  
N.T.S.

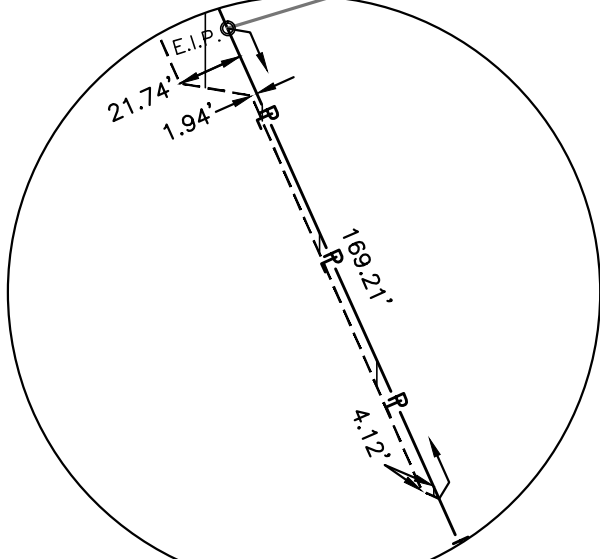

Permanent Right of Way		
Line Table		
Line #	Direction	Length
L1	N53°41'43"E	57.06
L2	S65°06'13"E	137.44
L3	S24°18'18"E	76.52
L4	N65°06'13"W	222.86

Centerline of Pipeline		
Line Table		
Line #	Direction	Length
L5	S65°06'13"E	180.53

SEE SHEET 1 OF 2 FOR GRAPHICS AND LABELS

NO.	TRACT NO.	OWNERSHIP	DEED BOOK	PAGE
1	PO-055.000	MICHAEL A. SUTTON AND WIFE, ELIZABETH A. SUTTON	311	278
2	PO-056.000	MICHAEL A. SUTTON AND WIFE, ELIZABETH A. SUTTON	311	278
3	PO-057.000	PORTER CAPITAL CORPORATION	365	1573
4	PO-059.000	WILLIAM G. SMITH AND WIFE, BARBARA A. SMITH	242	253
5	PO-061.000	WILLIAM G. SMITH AND WIFE, BARBARA A. SMITH	265	1370
6	PO-062.000	WILLIAM F. KRAUS III AND WIFE, EILEEN M. KRAUS	391	1338-1340
7	PO-063.000	CLARENCE W. BRADLEY AND WIFE, ELIZABETH H. BRADLEY	243	262

SEE SHEET 1 FOR THE LAND SURVEYOR'S CERTIFICATION, SEAL AND SIGNATURE.

**EASEMENT SURVEY**  
 FPR PSNC ENERGY - T-001 REPLACEMENT  
 COOPER GAP & WHITE OAK TOWNSHIP  
 POLK COUNTY, NORTH CAROLINA

SURFACE SITE IN PROPERTY OF  
 STATE OF NORTH CAROLINA  
 GREEN RIVER COVE ROAD, SALUDA, N.C.  
 PO-058.000  
 DEED BOOK 226, PAGE 1813  
 53020-35-058

Drawn By: S.B.B.	Chk'd By: RJW	App'd By: JMS	Proj. No. 53020000	Scale: N.T.S.
Drawn Date: 07/15/15			Sheet: 1 OF 2	PSNC Proj. No. 0059354

REVISIONS				
No.	Date	Rev By	Description	Checked

**TEMPORARY EASEMENT**

Prepared By:  
Public Service of North Carolina, Incorporated  
Return To:  
SCANA Corporation  
Attn: Craig Bodie  
800-A Gaston Rd.  
Gastonia, NC 28056

Line No.	<u>T-001A Replacement</u>
Parcel No.	<u>P30-3</u>
R/W No.	<u>PO-058</u>
Project No.	<u>0059354</u>
Check No.	<u>                    </u>
Date of Check	<u>                    </u>

STATE OF NORTH CAROLINA  
COUNTY OF POLK

Know all men by these presents that for and in consideration of the sum of Ten Dollars (\$10.00) and other valuable consideration paid to **State of North Carolina** ("**Grantor**", whether one or more), the receipt of which is hereby acknowledged, Grantor hereby conveys unto **PUBLIC SERVICE COMPANY OF NORTH CAROLINA, INCORPORATED**, a South Carolina corporation d/b/a **PSNC ENERGY**, and its successors and assigns ("**PSNC**"), a temporary and exclusive easement for pipeline construction activities and storage of materials, equipment, and vehicles related to the initial construction of PSNC's pipeline facilities on land adjacent to or near the lands of Grantor, or in which Grantor has an interest, situate in Cooper Gap and White Oak Township, Polk County, North Carolina, as described in that instrument recorded in Book 226, Page 1813, Polk County Registry ("**Grantor's Land**"). The easement granted herein shall be located as shown on **Exhibit A** attached hereto and incorporated herein (the "**Easement Area**").

PSNC shall have all rights necessary and convenient for exercising the rights granted herein, including, but not limited to, the right of ingress and egress over and across the Easement Area and Grantor's Land for access to and from the Easement Area and the right from time to time to cut all trees, shrubs, and undergrowth, and to clear other obstructions located within the Easement Area. In exercising the right of ingress and egress outside of the Easement Area granted herein, PSNC shall use its best efforts to cause the least practicable interference with Grantor's use of Grantor's Land and use existing roads and driveways to the extent reasonably practicable. PSNC shall comply with all applicable federal, state, and local laws, ordinances, and regulations in exercising the rights granted herein.

No permanent installation will be made within the Easement Area, and all materials and improvements placed by PSNC within the Easement Area shall be and remain the property of PSNC and shall be removed upon completion of the project. Upon completion of the project, PSNC shall be responsible for the repair of any damages caused by PSNC, its successors and assigns, and shall restore and level the surface of the Easement Area to, as nearly as can reasonably be done, the same condition as prior to any such operations so that there shall not be any permanent mounds, ridges, sinks, or trenches.

The PSNC shall have the right to assign this Easement and the rights granted herein in whole or in part at any time and from time to time.

To have and to hold said Easement unto PSNC, its successors and assigns, forever, and Grantor, for itself, its heirs, executors, administrators, successors, and assigns, covenants to and with PSNC that Grantor is lawfully seized of Grantor's Land and the Easement Area in fee and has the right to convey said rights and Easement and that Grantor will forever warrant and forever defend the title to said rights and Easement against the lawful claims of all persons whomsoever. The individuals signing this Easement personally warrant that they have the right and power to enter into this Easement, to grant the rights granted under this Easement, and to undertake the obligations described in this Easement.

It is understood and acknowledged by the undersigned that the person securing this grant on behalf of PSNC is without authority to make any agreement with regard to the subject matter hereof which is not expressed herein, and that no such agreement will be binding on PSNC.

Temporary land rights will expire upon completion of the project or December 31, 2016, whichever occurs first.

***[Signature Page(s) Follow]***

**IN WITNESS WHEREOF**, this **TEMPORARY EASEMENT** is executed this \_\_\_\_\_ day of \_\_\_\_\_, 2015.

Subscribing Witnesses: (Optional)

**GRANTOR:**

\_\_\_\_\_ Sign

\_\_\_\_\_ Sign

\_\_\_\_\_ Print

\_\_\_\_\_ Print

\_\_\_\_\_ Sign

\_\_\_\_\_ Sign

\_\_\_\_\_ Print

\_\_\_\_\_ Print

\_\_\_\_\_ Sign

\_\_\_\_\_ Sign

\_\_\_\_\_ Print

\_\_\_\_\_ Print

\_\_\_\_\_ Sign

\_\_\_\_\_ Sign

\_\_\_\_\_ Print

\_\_\_\_\_ Print

***[Notary Page(s) Follow]***

USE STANDARD ACKNOWLEDGMENT UNLESS THERE ARE SUBSCRIBING WITNESSES

STANDARD ACKNOWLEDGMENT

STATE OF NORTH CAROLINA

COUNTY OF \_\_\_\_\_

I, \_\_\_\_\_, a Notary Public of \_\_\_\_\_ County, North Carolina, do hereby certify that

\_\_\_\_\_, GRANTOR, personally appeared before me this day and acknowledged the due execution of the foregoing TEMPORARY EASEMENT.

Witness my hand and seal this \_\_\_\_\_ day of \_\_\_\_\_, 2015.

\_\_\_\_\_  
Notary Public Sign  
\_\_\_\_\_  
Print

My Commission Expires: \_\_\_\_\_

SUBSCRIBING WITNESS ACKNOWLEDGMENT

STATE OF NORTH CAROLINA

COUNTY OF \_\_\_\_\_

I, \_\_\_\_\_, a Notary Public of \_\_\_\_\_ County, North Carolina, do hereby certify that \_\_\_\_\_

(subscribing witness) personally appeared before me this day and being duly sworn, stated that in his (her) presence \_\_\_\_\_,

GRANTOR, acknowledged the due execution of the foregoing TEMPORARY EASEMENT.

Witness my hand and seal this \_\_\_\_\_ day of \_\_\_\_\_, 2015.

\_\_\_\_\_  
Notary Public Sign  
\_\_\_\_\_  
Print

My Commission Expires: \_\_\_\_\_

# EXHIBIT A

## NOTES

1. ALL DISTANCES ARE HORIZONTAL GROUND DISTANCES.
2. AREAS DETERMINED BY COORDINATE METHOD.
3. AREAS SHOWN ARE SUBJECT TO EASEMENT OF RECORD.
4. RECORD REFERENCES: DEED BOOK 226, PAGE 1813.
5. PARCEL I.D. No. P30-3.
6. PROPERTY LINES SHOWN ARE BASED ON EXISTING DEEDS, PLATS AND VISIBLE MONUMENTATION DISCOVERED ALONG PROJECT AREA.
7. THIS SURVEY IS REFERENCED TO THE NORTH CAROLINA STATE PLANE COORDINATE SYSTEM NAD83 (2011).
8. ALL CORNERS ARE AS NOTED.
9. THIS PLAT IS FOR EASEMENT ACQUISITION PURPOSES ONLY AND IS NOT TO BE CONSIDERED A BOUNDARY SURVEY OF THE PARENT TRACT.
10. ALL TEMPORARY LAND RIGHTS WILL EXPIRE ON DECEMBER 31, 2016.

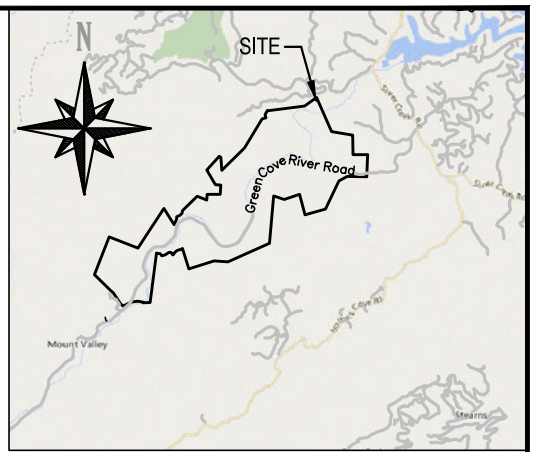
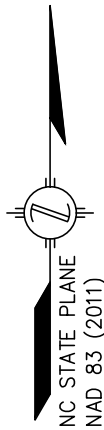

VICINITY MAP (NTS)

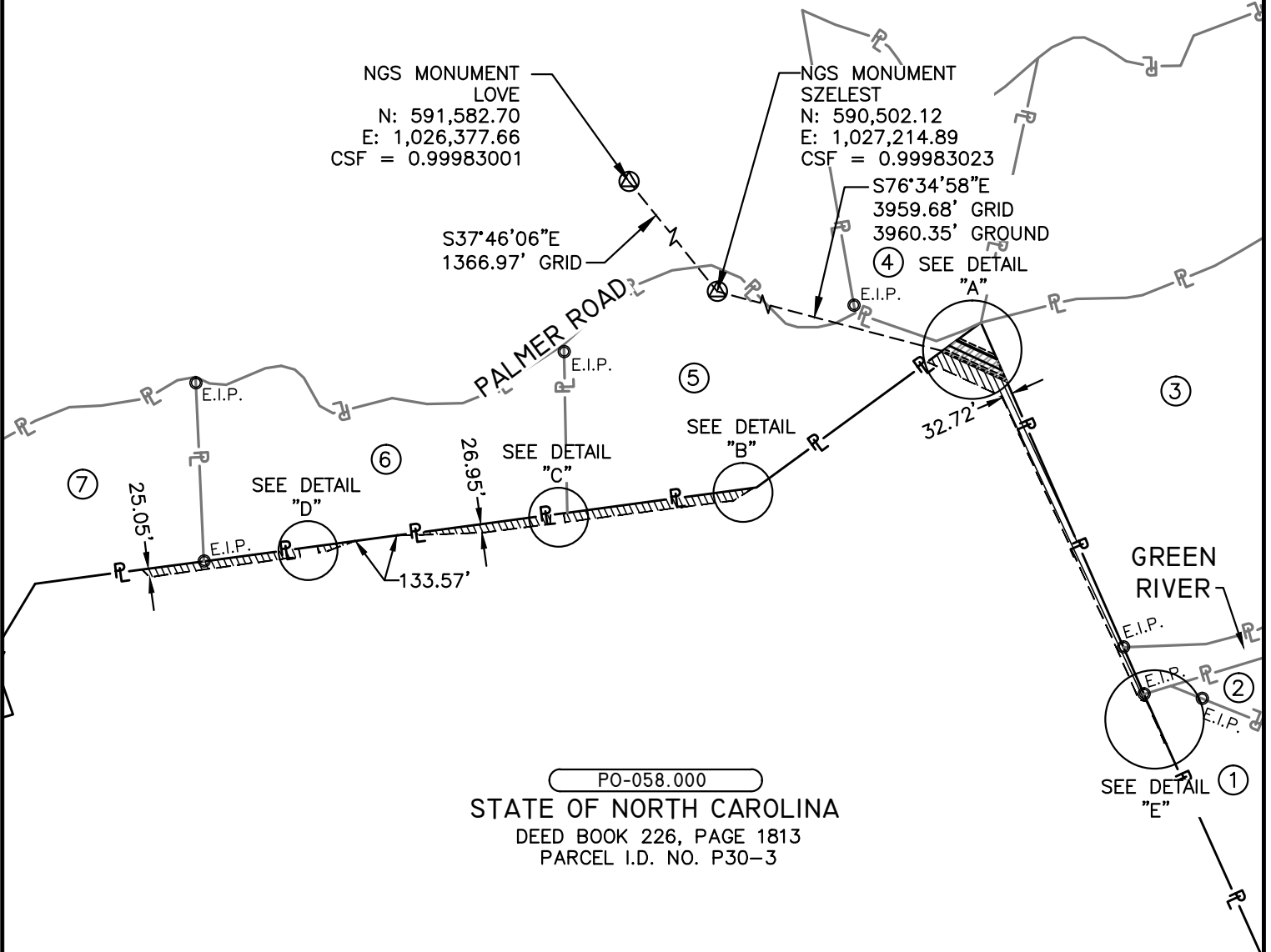

## LEGEND

- NGS MONUMENT
- EIP EXISTING IRON PIPE OR PIN
- IPS IRON PIN SET
- CP COMPUTED POINT
- LINE NOT TO SCALE
- R.O.W. RIGHT OF WAY
- PERMANENT RIGHT OF WAY
- TEMPORARY WORKSPACE
- ADDITIONAL TEMPORARY WORKSPACE
- EXISTING EASEMENT



I, John M. Story, certify that this plat was drawn under my supervision from an actual survey performed under my supervision (deed description recorded in Deed Book 226, Page 1813; that the ratio of precision as calculated is 1:10,000±; that the Global Positioning System (GPS) observations were performed to the Geospatial Positioning Accuracy Standards, Part 2: Standards for Geodetic Networks at the Class "A" accuracy classification (95% confidence) using RTK Network/ OPUS and traditional traverse.

That this plat meets the requirements of G.S. 47-30 section (f)(11)(d).

This 30 day of July, 2015.

*John M. Story*  
JOHN M. STORY, PLS L-3840

DONALDSON, GARRETT & ASSOCIATES, INC.  
9471-L SOUTHERN PINE BOULEVARD  
CHARLOTTE, N.C. 28273  
PH: (704) 374-1955 john.story@dg-anc.com  
NC CORPORATE LICENSE No. C-1518

SEE SHEET 2 OF 2 FOR  
LINE TABLES, DETAILS  
AND OWNERSHIP TABLE  
STATE OF NORTH CAROLINA

	sq. ft.	acres
AREA OF PERMANENT EASEMENT:	8,976±	0.21±
AREA OF TEMPORARY WORKSPACE:	80,241±	1.84±

	feet	rods
LENGTH OF PIPELINE:	180.53	10.94

EASEMENT SURVEY FPR PSNC ENERGY - T-001 REPLACEMENT COOPER GAP & WHITE OAK TOWNSHIP POLK COUNTY, NORTH CAROLINA				
SURFACE SITE IN PROPERTY OF STATE OF NORTH CAROLINA GREEN RIVER COVE ROAD, SALUDA, N.C. PO-058.000 DEED BOOK 226, PAGE 1813 53020-35-058				
Drawn By: S.B.B.	Chk'd By: R.J.W.	App'd By: J.M.S.	Proj. No. 53020000	Scale: 1"=600'
Drawn Date: 07/15/15			Sheet: 1 OF 2	PSNC Proj. No. 0059354
600 300 0 600 GRAPHIC SCALE IN FEET				
REVISIONS				
No.	Date	Rev By	Description	Checked

# EXHIBIT A

DETAIL "A"  
N.T.S.

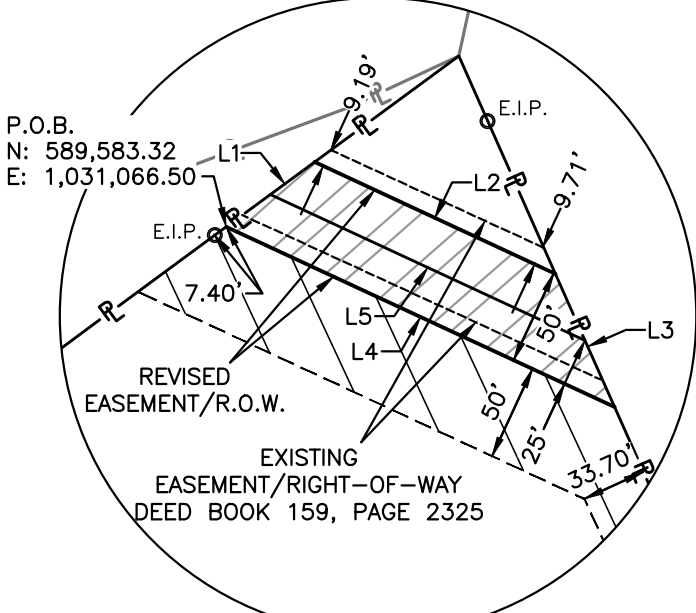

DETAIL "B"  
N.T.S.

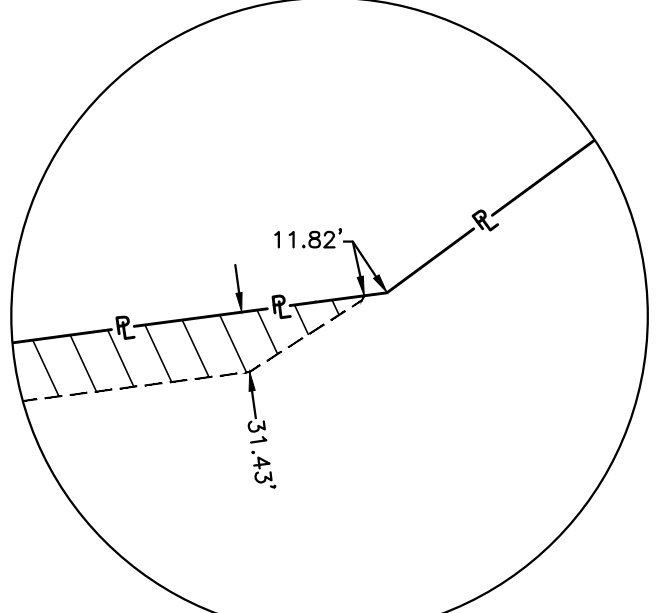

DETAIL "C"  
N.T.S.

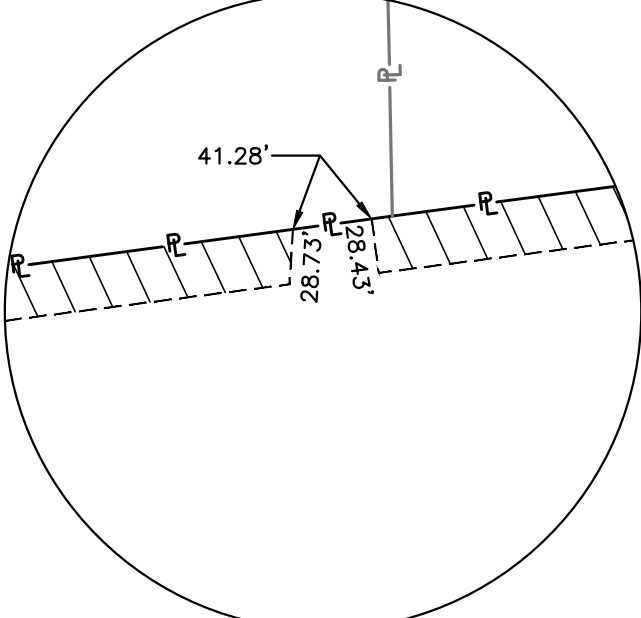

DETAIL "D"  
N.T.S.

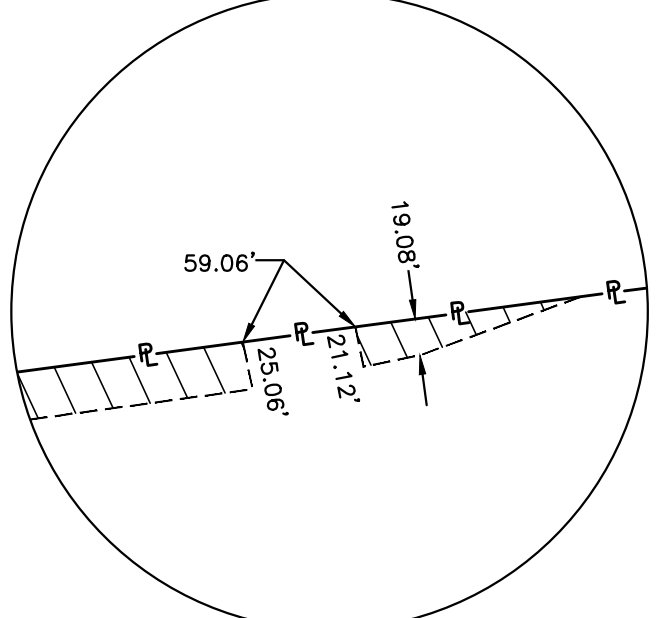

DETAIL "E"  
N.T.S.

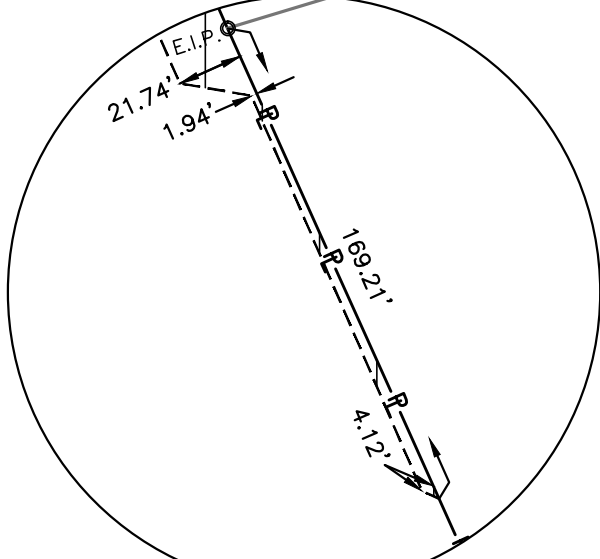

Permanent Right of Way		
Line Table		
Line #	Direction	Length
L1	N53°41'43"E	57.06
L2	S65°06'13"E	137.44
L3	S24°18'18"E	76.52
L4	N65°06'13"W	222.86

Centerline of Pipeline		
Line Table		
Line #	Direction	Length
L5	S65°06'13"E	180.53

SEE SHEET 1 OF 2 FOR GRAPHICS AND LABELS

NO.	TRACT NO.	OWNERSHIP	DEED BOOK	PAGE
1	PO-055.000	MICHAEL A. SUTTON AND WIFE, ELIZABETH A. SUTTON	311	278
2	PO-056.000	MICHAEL A. SUTTON AND WIFE, ELIZABETH A. SUTTON	311	278
3	PO-057.000	PORTER CAPITAL CORPORATION	365	1573
4	PO-059.000	WILLIAM G. SMITH AND WIFE, BARBARA A. SMITH	242	253
5	PO-061.000	WILLIAM G. SMITH AND WIFE, BARBARA A. SMITH	265	1370
6	PO-062.000	WILLIAM F. KRAUS III AND WIFE, EILEEN M. KRAUS	391	1338-1340
7	PO-063.000	CLARENCE W. BRADLEY AND WIFE, ELIZABETH H. BRADLEY	243	262

SEE SHEET 1 FOR THE LAND SURVEYOR'S CERTIFICATION, SEAL AND SIGNATURE.

**EASEMENT SURVEY**  
 FPR PSNC ENERGY - T-001 REPLACEMENT  
 COOPER GAP & WHITE OAK TOWNSHIP  
 POLK COUNTY, NORTH CAROLINA

SURFACE SITE IN PROPERTY OF  
 STATE OF NORTH CAROLINA  
 GREEN RIVER COVE ROAD, SALUDA, N.C.  
 PO-058.000  
 DEED BOOK 226, PAGE 1813  
 53020-35-058

Drawn By: S.B.B.	Chk'd By: RJW	App'd By: JMS	Proj. No. 53020000	Scale: N.T.S.
Drawn Date: 07/15/15			Sheet: 1 OF 2	PSNC Proj. No. 0059354

REVISIONS

No.	Date	Rev By	Description	Checked

# EXHIBIT G-1

December 10, 2015



## 15A NCAC 10F .0347(a)(5) – City of Havelock Application for No Wake Zone Slocum Creek

The City of Havelock in Craven County submitted an application and a certified Resolution requesting that the NC Wildlife Resources Commission promulgate rulemaking for an amendment to 15A NCAC 10F.0347, to establish a no wake zone on a portion of Slocum Creek.

Staff investigated and found that the no wake zone is necessary to mitigate hazards created by motorboats entering and exiting Slocum Creek at the boat ramp at the U.S. 70 bridge. The City of Havelock is building a kayak/canoe launch northeast of the ramp. Paddle boat enthusiasts in the narrow and winding waters northeast of the ramp, with limited sightlines, create the need to reduce motorboat speeds for a distance of approximately 1650 feet as shown on the attached map.

Staff therefore recommends Commission approval to submit the Notice of Text highlighted below in the *North Carolina Register* for at least 60 days, with one public hearing as required under the Administrative Procedure Act. After the comment period has ended, the proposed amendment will be brought before the WRC for consideration of adoption.

### 15A NCAC 10F .0347 CRAVEN COUNTY

(a) Regulated Areas. This Rule applies to the following waters in Craven County:

- (1) that portion of Northwest Creek between the entrance buoys at Fairfield Harbour Marina and the mouth of Spring Creek, and to all of Spring Creek, including the bulkheaded area of Fairfield Harbour, in Craven County;
- (2) that area of water between the entrance buoys of the Olde Towne Lake, from the Trent River and including all of Olde Towne Lake and the bulkhead area of Olde Towne Harbour itself;
- (3) Matthews Point Marina. That triangular portion within 300 feet on either side and 150 feet straight off of the main pier at Matthews Point Marina located on Clubfoot and Mitchell Creeks, at the end of SR 1711 in the Harlowe area of Craven County;
- (4) that area of water within 50 yards of the fuel dock at Eastern Carolina Yacht Club Club; and
- (5) that portion of Slocum Creek in the City of Havelock, shore to shore east of a line from a point on the northern shore at 34.89122 N, 76.92302 W to a point on the southern shore at 34.89102 N, 76.92304 W and extending northeast, shore to shore to a line from a point on the northern shore at 34.8937 N, 76.92109 W to a point on the southeast shore at 34.89358 N, 76.92089 W.

(b) Speed Limit. No person shall operate any vessel at greater than no-wake speed within the regulated areas described in Paragraph (a) of this Rule.

(c) Green Springs Boys Club Swimming Area - No person shall operate a vessel within the Green Springs Boys Club Swimming Area along the Neuse River as designated by marker buoys and float lines.

(d) Placement and Maintenance of Markers. The Board of Commissioners of Craven County is hereby designated a suitable agency for placement and maintenance of the markers implementing this Rule, Subparagraphs (1), (2), (3), and (4) of this Rule, subject to the approval of the United States Coast Guard and the United States Army Corps of Engineers.

(e) The City of Havelock is hereby designated a suitable agency for placement and maintenance of the markers implementing Subparagraph (5) of this Rule, subject to the approval of the United States Coast Guard and the United States Army Corps of Engineers.





Proposed No Wake Zone  
Existing No Wake Zone  
New Alignment  
EXHIBIT 2A

0 125 250 Feet

Entry/Exit Sign

Marker Buoy

Marker Buoy

Marker Buoy

Entry/Exit Sign

Boat Ramp

70

70

**City of Havelock**  
**Department of**  
**Planning and Code Enforcement**  
**1 Governmental Avenue**  
**Havelock, NC 28532**  
**252-444-6433**



November 16, 2015

NC Wildlife Resources Commission  
Attn: Kate Pipkin, No Wake Zone Coordinator  
1722 Mail Service Center  
Raleigh, NC 27699-1701

Dear Ms. Pipkin:

During its regularly scheduled meeting on October 26, 2015, the City of Havelock Board of Commissioners held a public hearing about a No Wake Zone proposal for Slocum Creek in Havelock, North Carolina. Subsequently, the Board adopted a resolution requesting the Wildlife Resources Commission to take action on the proposal.

The following documents are being submitted for your consideration of the request:

- Certified Resolution adopted October 26, 2015 for "No Wake" signs
- Completed Form D-1
- Two copies of a map showing the area to be marked
- Picture of "No Wake" signs to be furnished by the City of Havelock
- Copy of Legal Advertising of Public Hearing published in the Sun Journal, on October 7 and 14, 2015.

In addition to the request for the regulatory signs in the No Wake Zone area, the City proposes to install a cautionary sign at the entrance to this prong of the creek to alert boaters to the narrow waters and high paddle sports activity. A copy of the proposed signage and map is also included. The City understands this is strictly cautionary and is not under the NC Wildlife Commission's regulatory authority.

If any additional information is required, please contact me at 252-444-6411.

Sincerely,

A handwritten signature in black ink that reads "Katrina F. Marshall".

Katrina F. Marshall, AICP  
Director of Planning and Code Enforcement

cc: Cindy Morgan, Clerk to the Board

# EXHIBIT G-2

December 10, 2015



## Fiscal Note Review of Proposed Wildlife Resources Commission No-Wake Zone Rule 15A NCAC 10F .0347

Contact: Erica Garner, Agency Legal Counsel and Rule-making Coordinator  
1701 Mail Service Center  
Raleigh, N.C 27699-1701  
(919) 707-0014  
erica.garner@ncwildlife.org

Impact: State Government: No  
Local Government: Yes  
Substantial Impact: No

Authority: G.S. 75A-3: 75A-15

The proposed permanent amendment to 15A NCAC 10F .0347 (APPENDIX 1) establishes one no wake zone on a portion of Slocum Creek in the City of Havelock, Craven County.

The City of Havelock made formal application to the Wildlife Resources Commission requesting a no wake zone on a portion of Slocum Creek shore to shore, beginning at the boat ramp at the U.S. 70 bridge northeast for a distance of approximately 1650 feet.

The Commission reviewed the application and believes that the no wake zone is necessary to mitigate safety hazards created by motorboats entering and exiting a portion of Slocum Creek northeast of the boat ramp. The City of Havelock is building a kayak/canoe launch northeast of the ramp. Paddle boat enthusiasts in these narrow and winding waters, with limited sight lines in the highlighted area of Slocum Creek, create the need to reduce motorboat speeds in the area.

The City of Havelock will mark the no wake zone and purchase and maintain the buoys at a cost of no more than \$2,000.

**State Impact Analysis:** None.

**Local Impact Analysis:** The City of Havelock will purchase, place and maintain the buoys to mark the no wake zone, at a cost of no more than \$2,000.

**Substantial Economic Impact:** There will be no substantial economic impact to the public.

## APPENDIX 1

### 15A NCAC 10F .0347 CRAVEN COUNTY

(a) Regulated Areas. This Rule applies to the following waters in Craven County:

- (1) that portion of Northwest Creek between the entrance buoys at Fairfield Harbour Marina and the mouth of Spring Creek, and to all of Spring Creek, including the bulkheaded area of Fairfield Harbour, in Craven County;
- (2) that area of water between the entrance buoys of the Olde Towne Lake, from the Trent River and including all of Olde Towne Lake and the bulkhead area of Olde Towne Harbour itself;
- (3) Matthews Point Marina. That triangular portion within 300 feet on either side and 150 feet straight off of the main pier at Matthews Point Marina located on Clubfoot and Mitchell Creeks, at the end of SR 1711 in the Harlowe area of Craven County;
- (4) that area of water within 50 yards of the fuel dock at Eastern Carolina Yacht Club Club.
- (5) that portion of Slocum Creek in the City of Havelock, shore to shore east of a line from a point on the northern shore at 34.89122 N, 76.92302 W to a point on the southern shore at 34.89102 N, 76.92304 W and extending northeast, shore to shore to a line from a point on the northern shore at 34.8937 N, 76.92109 W to a point on the southeast shore at 34.89358 N, 76.92089 W.

(b) Speed Limit. No person shall operate any vessel at greater than no-wake speed within the regulated areas described in Paragraph (a) of this Rule.

(c) Green Springs Boys Club Swimming Area - No person shall operate a vessel within the Green Springs Boys Club Swimming Area along the Neuse River as designated by marker buoys and float lines.

(d) Placement and Maintenance of Markers. The Board of Commissioners of Craven County is hereby designated a suitable agency for placement and maintenance of the markers implementing this Rule, Subparagraphs (1), (2), (3), and (4) of this Rule, subject to the approval of the United States Coast Guard and the United States Army Corps of Engineers.

(e) The City of Havelock is hereby designated a suitable agency for placement and maintenance of the markers implementing Subparagraph (5) of this Rule, subject to the approval of the United States Coast Guard and the United States Army Corps of Engineers.

*History Note: Authority G.S. 75A-3; 75A-15;  
Eff. August 1, 1984;  
Amended Eff. December 1, 1990; October 1, 1989; June 1, 1989;  
Temporary Amendment Eff. April 1, 1998;  
Amended Eff. July 1, 2016; July 1, 1998.*